

# Planetary gears.

Standard series & custom engineered solutions.

 **FramoMorat**  
Franz Morat Group

**WEB-Shop**  
buy online



## - Our motto -

Customers trust us as their preferred partner for gear and drive engineering.  
We stand for quality, innovation, efficiency and reliability.



### Design

The selection of an appropriate planetary gear for your individual application. Contact us by phone or via the inquiry form on [www.framo-morat.com](http://www.framo-morat.com)

### Short delivery time

Small quantities available on short notice. Delivery time for larger quantities or special requests has to be checked individually

### CAD drawings

Drawings for all series are available on request

### Flexibility

For customized solutions we draw from a large range of single components. Depending on demand they may be combined for you in a flexible way

# Your satisfaction is our ultimate goal.

Our services in every aspect of the planetary gear.

Framo Morat is not only known for its comprehensive manufacturing expertise. Our customers also revere us as experienced partners in drive technology. This expertise is the foundation of our planetary gear series.

We place great importance on your flexibility in the configuration and application of our planetary gears. Being faithful to our motto customer satisfaction is always a priority.

## Quality

Our high quality standards apply to all our planetary gearbox series. These include especially high gearing quality, low backlash and long service life.

## Innovation

Fast response to customer requests and constant further development of our planetary gears is our driving force. Do you have special requirements? We will gladly elaborate with you innovative solutions and drive concepts.

## Profitability

Planetary gears are known for their high efficiency. Owing to the high manufacturing quality of our gearbox series we offer you an excellent price-performance ratio.

## Reliability

Our planetary gears accomplish reliable performance in their numerous applications. Being your reliable partner and supplier is our constant driving force.

## Flexibility

We offer you the highest form of flexibility in motor integration through our versatile product range with mounting flanges and reduction sleeves. The results are drive solutions for industries like mechanical engineering, medical technology, energy generation or building technology.

Or do you require an individual solution? Together we will develop innovative drive solutions of tomorrow.

## What can we do for you?

We are glad to be personally there for you and we look forward to common challenges and projects:

 +49 7657 88 303  [drives@framo-morat.com](mailto:drives@framo-morat.com)  [shop.framo-morat.com/en/Planetary-gearbox](https://shop.framo-morat.com/en/Planetary-gearbox)

### Custom engineered solutions

We will accompany you from the specification to the series!  
We will employ decades of experience in development of custom engineered drives

### Repair service

We will take over inspection and maintenance for you

### Web-Shop

Our planetary gears are now available online

### Production

Do you have individual requirements?  
• We integrate the entire process chain - metalworking, quality control & assembling - on our own premises

### Personal contacts

We support you internationally! We look forward to receiving questions about planetary gears via phone or email

## Planetary gears • Overview

		High-End				
Diameter Gearbox (mm)		GSA 50 / 70 / 90 / 120 / 160	GSB 44 / 62 / 90 / 120 / 142 / 180	GSF 62 / 75 / 100 / 142 / 180	GSD 47 / 64 / 90 / 110 / 140	GSBL 44 / 62 / 90 / 120 / 142 / 180
Nominal output torque (Nm)		18 - 656	14 - 1266	45 - 1266	17 - 683	14 - 1266
Acceleration torque (Nm)		32 - 1181	25 - 2279	81 - 2279	30 - 1229	25 - 2279
Emergency stop torque (Nm)		54 - 1968	41 - 3799	135 - 3798	50 - 2048	41 - 3799
Transmission	1-st.	3, 4, 5, 7, 10	3, 4, 5, 7, 8, 10	3, 4, 5, 7, 10	4, 5, 7, 10	3, 4, 5, 7, 10, 16, 20
	2-st.	15, 20, 25, 30, 35, 40, 50, 70, 100	15, 20, 25, 30, 35, 50, 60, 70, 80, 100	15, 20, 25, 30, 35, 40, 50, 70, 100	20, 25, 35, 40, 50, 70, 100	25, 30, 50, 70, 100, 140, 180, 200
Backlash (arcmin)	1-st.	<=3 (opt. <=1)	<=3 (opt. <=1)	<=3 (opt. <=1)	<=3 (opt. <=1)	<=4 (opt. <=2)
	2-st.	<=5 (opt. <=3)	<=5 (opt. <=3)	<=5 (opt. <=3)	<=5 (opt. <=3)	<=7 (opt. <=4)

**GSA**

- Low backlash for highest precision, standard as low as <=3 arcmin, optional as low as <= 1 arcmin
- High radial and axial forces permissible
- Simple mounting without intermediate flange

**GSB**

- Transmission of high torques in a small space
- Space- and weight-optimized 2-stage design
- Corrosion protection for entire housing incl. output side

**GSF**

- High load level due to double bearings
- High torsional rigidity
- Optimum protection against dust particles and water jets

**GSD**

- Compact design and rigid connection due to robotic flange
- Highest torsional rigidity
- Highest axial loads due to optional tapered roller bearings

**GSBL**

- Right angle version for space restricted applications
- High torque level
- Up to ratio i = 200 in 2-stage version



## Selection criteria

Gearbox characteristics	GSA	GSB	GSF	GSD	GSBL
Rotational speed	✓ ✓ ✓	✓ ✓ ✓	✓ ✓ ✓	✓ ✓ ✓	✓ ✓ ✓
Torque	✓ ✓ ✓	✓ ✓ ✓	✓ ✓ ✓	✓ ✓ ✓	✓ ✓ ✓
Range of transmission ratios	✓ ✓	✓ ✓	✓ ✓	✓ ✓	✓ ✓ ✓
Backlash	✓ ✓ ✓	✓ ✓ ✓	✓ ✓ ✓	✓ ✓ ✓	✓ ✓ ✓
Lifetime	✓ ✓ ✓	✓ ✓ ✓	✓ ✓ ✓	✓ ✓ ✓	✓ ✓ ✓
Protection class	✓ ✓ ✓	✓ ✓ ✓	✓ ✓ ✓	✓ ✓ ✓	✓ ✓ ✓
Radial force	✓ ✓ ✓	✓ ✓	✓ ✓ ✓	✓ ✓ ✓	✓ ✓
Axial force	✓ ✓ ✓	✓ ✓	✓ ✓ ✓	✓ ✓ ✓	✓ ✓
Noise	✓ ✓	✓ ✓ ✓	✓ ✓ ✓	✓ ✓ ✓	✓ ✓
Weight	✓ ✓	✓ ✓	✓ ✓	✓ ✓	✓

High-End Economy	
GSN 50 / 60 / 70 / 80 / 90 / 115 / 160	GFE 50 / 70 / 90 / 120 / 145 / 180 / 220
13 - 688	13 - 1562
22 - 1125	24 - 2812
38 - 2063	40 - 4686
3, 4, 5, 7, 10	3, 4, 5, 7, 10
15, 20, 25, 30, 35, 40, 50, 70, 100	15, 20, 25, 30, 35, 40, 50, 70, 100
<=7	<=7
<=10	<=10

Customer-specific planetary gears
...individually developed for you in accordance with the following parameters:
<ul style="list-style-type: none"> <li>▪ Gearbox sizes</li> <li>▪ Gear stages</li> <li>▪ Gear ratios</li> <li>▪ Gear types</li> <li>▪ Bearings</li> <li>▪ Materials</li> <li>▪ Lubrication</li> <li>▪ Interfaces</li> <li>▪ etc.</li> </ul>

### GSN

- Low noise level due to ground helical gearing
- High power density
- Protection class IP65



### GFE

- Big housing sizes up to 220 mm
- Max. input speed up to 10,000 rpm
- 30,000 h life time



### Custom planetary gears

- Individualized design of material, diameter, bearing, tooth width, etc. on each planetary carrier
- Error-free connection to all interfaces
- Drive integration into your entire system taking into account the mechanics, electronics and control technology



GSN	GFE
✓ ✓ ✓	✓ ✓ ✓
✓ ✓	✓ ✓
✓ ✓	✓ ✓
✓ ✓	✓ ✓
✓ ✓ ✓	✓ ✓ ✓
✓ ✓ ✓	✓ ✓ ✓
✓ ✓	✓ ✓
✓ ✓	✓ ✓
✓ ✓ ✓	✓ ✓
✓ ✓	✓

Custom
✓ ✓ ✓
✓ ✓ ✓
✓ ✓ ✓
✓ ✓ ✓
✓ ✓ ✓
✓ ✓ ✓
✓ ✓ ✓
✓ ✓ ✓
✓ ✓ ✓
✓ ✓ ✓
✓ ✓ ✓

# The G-series.

Low-backlash planetary gears - compact and highly precise.

## Bearing system

Standard use of maximum preloaded deep groove ball bearings. Optionally, the GSD line is also available with double taper roller bearings to accommodate higher radial and axial forces. For the GSF line the double taper roller bearings are standard.

## One-piece planetary carrier

All planetary carriers are manufactured as a cage made from solid material. This increases quiet operating characteristics while at the same time improving positioning accuracy and reducing backlash.

## Sun pinion bearing system

In the high-end gearbox range, the sun pinions are fitted with an additional bearing system in order to ensure quieter operating behavior.

## Sealing

An additional shaft sealing ring ensures maximum dust and splash water protection in accordance with protection class IP65 in all lines.

## Special coating

Optimum corrosion protection also for the output side.

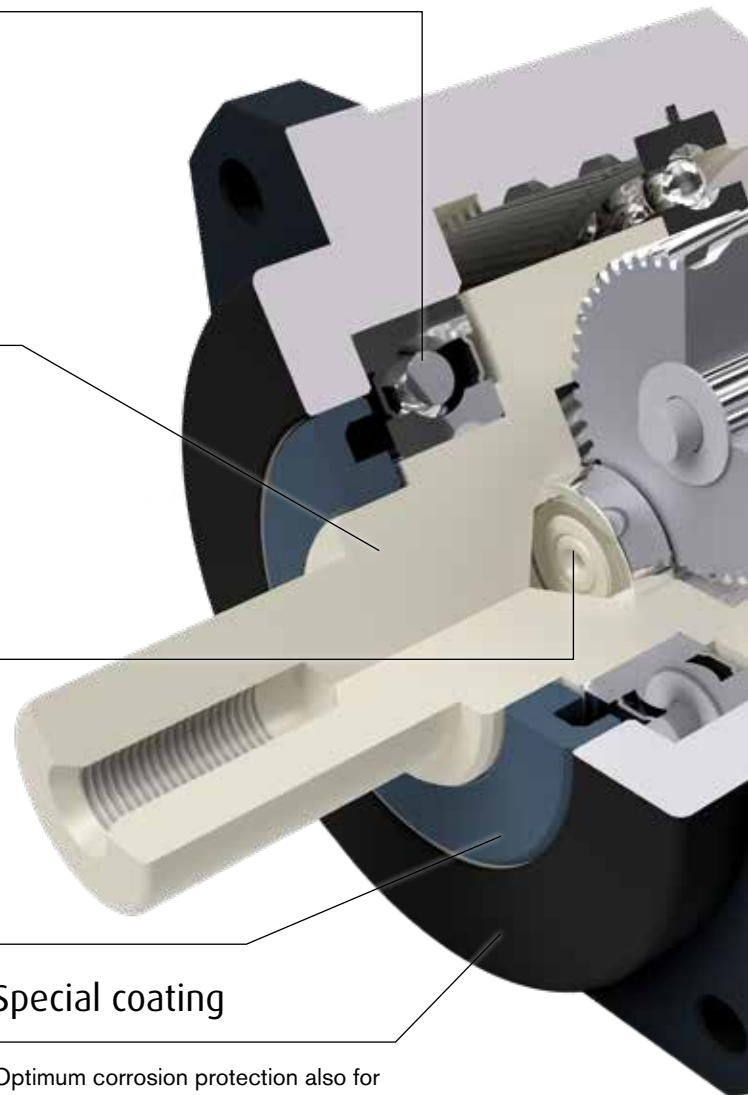

## G-series - High-End & High-End Economy range

The G-series includes the high-end gearbox lines GSD (flange gear), GSA, GSB & GSF (inline) and GSBL (angle gear) as well as the high-end economy GSN and GFE lines.

Particularly suitable applications for the G-series are those which place the highest demands on positioning accuracy, operating noises, running smoothness, bending rigidity and transmitted torque. The G-series is designed to meet the highest production requirements—all planetary gear sets are equipped with precision ground

helical gearing, single-piece planetary carriers and full needle bearings. Resolutely applied quality assurance measures consistently ensure that all high quality requirements are fulfilled at all times.

Particularly in the case of medium and large-volume projects, custom adaptations can also be made. We would be happy to develop your customized gearbox in accordance with your individual specifications.

## Full needle bearing

All lines have a full needle bearing, which has been especially designed for high torques.

## Helical cut components

All lines are equipped with ground, helical-cut precision components, which ensure low operating noise, very quiet operating characteristics and above-average torque absorption.

## Slotted hollow input shaft

Due to the high surface pressure, the slotted, two-piece hollow input shaft represents the ideal connection between the motor shaft and gearbox.

## Space-optimized 2 stage design

The high-end gearbox lines are constructed in a space-optimized, two-stage design. Due to the lower torque values, the input stage is dimensionally smaller than the output stage.

## Housing

The housings of the high end range are designed from a one-piece, robust housing. This improves the gear rigidity and enables the absorption of higher loads.

## Lubrication

The use of a synthetic fluid grease for optimal service life lubrication renders a grease refill unnecessary.

## Definition of serial number

Internal Group No.	Type	Size	Bearing	Backlash level	Input hollow shaft	Ratio				
3	-	GSA	090	-	1	-	24	-	005	
3	-	GSB	090	-	1	-	24	-	005	
3	-	GSF	090	-	1	-	24	-	005	
3	-	GSD	090	T	-	1	-	19	-	100
3	-	GSBL	120	-	1	-	28	-	010	
3	-	GSN	060	-	-	-	14	-	025	
3	-	GFE	090	-	-	-	24	-	005	

Bearing: with T = Tapered bearing; without T = Ball bearing (Tapered bearings are optional only for GSD)

Backlash level: 1 = Standard; 0 = Reduced backlash (Reduced backlash is not available for GSN and GFE)

Input hollow shaft diam. = Max. motorshaft diam. = D9 in gearbox dimensions

# Planetary gears GSA

The easy-to-mount high-end economy gearbox for high power transmissions.

The low-backlash planetary gearheads of the GSA series are designed for high positioning accuracy and highly dynamic cycle operation. Ground, helical toothed precision components inside the gear ensure low running noise and high running smoothness. Thanks to its robust design, the gear unit is convincing in applications in which large radial and axial forces are exerted. The hole pattern on the output side allows easy mounting.

## You benefit from:

- Low backlash for high precision, standard as low as  $\leq 3$  arcmin, optional as low as  $\leq 1$  arcmin
- High torque level
- Best corrosion protection also for output side
- Long product lifetime up to 30,000 h
- High torsional rigidity



## Typical application example



### Backgauge drive for press brakes

Press brakes are used for bending sheet metal. For this purpose, a bending punch presses the sheet metal into a die which determines the bending angle. Modern press brakes, which are often CNC-controlled, can be used to fold and bend steel sheets several centimetres thick. The multi-axis backgauge used in the planetary gear of the GSA070 series ensures the exact positioning of the plates. This can be controlled to move repeatedly between bends to produce complex parts.

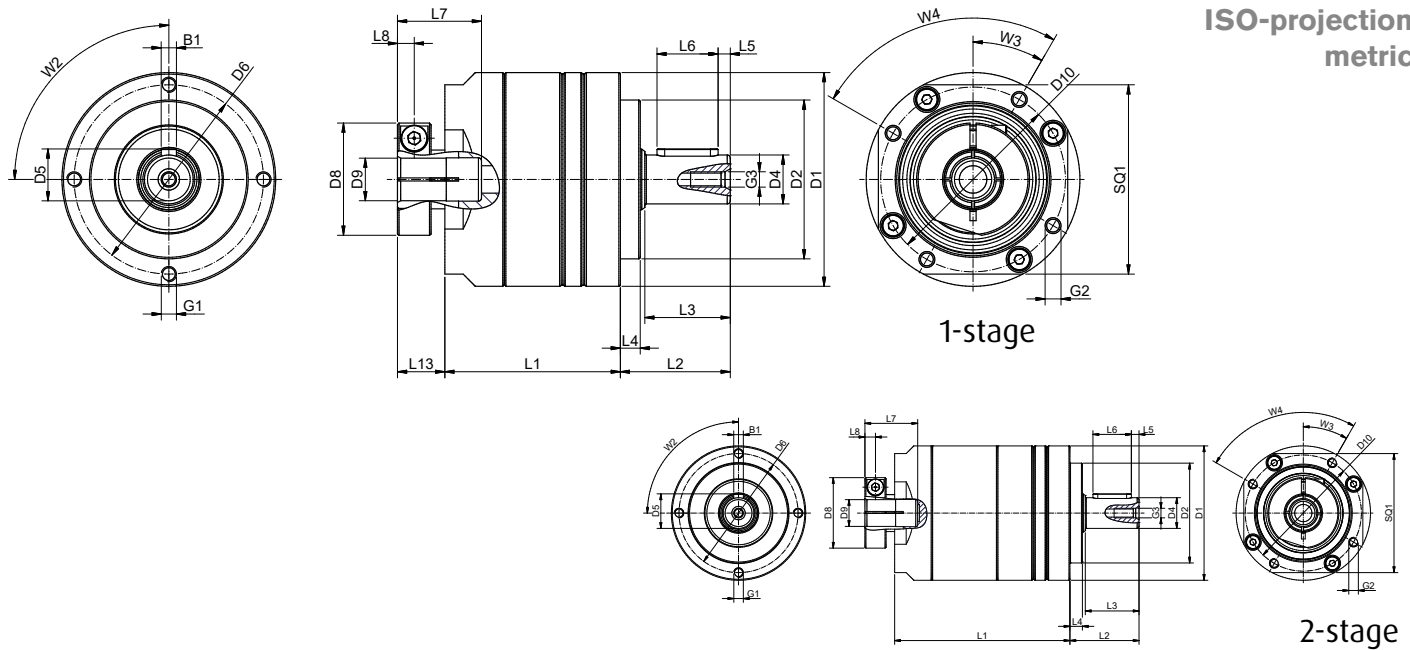
ISO-projection  
metric

## Planetary gears GSA • Dimensions

			GSA050	GSA070	GSA090	GSA120	GSA160
Housing diameter	D <sub>1</sub>		51	70	90	122	160
Centering diameter output	D <sub>2</sub>	h7	35	52	68	90	120
Output shaft diameter	D <sub>4</sub>	h6	14	16	22	32	40
Shaft height including feather key	D <sub>5</sub>		16	17	24,5	35	44
Hole circle diameter output	D <sub>6</sub>		44	62	80	108	140
Clamping system diameter	D <sub>8</sub>		28	37	49	67	67
Max. motor shaft diameter	D <sub>9</sub>	F7	14	14	24	28	32
Hole circle diameter input	D <sub>10</sub>		42	60,5	90	111	120
Housing length 1-stage	L <sub>1</sub>		55	57,5	83	101,5	115
Housing length 2-stage	L <sub>1</sub>		81	91,5	118	151,5	175
Shaft length output	L <sub>2</sub>		25,5	36	46	70	88
Shaft length from shoulder	L <sub>3</sub>		20	28	36	58	78
Centering depth output	L <sub>4</sub>		4	6,5	8	9	8
Distance from shaft end	L <sub>5</sub>		2,5	4	3	4	5
Feather key length	L <sub>6</sub>		15	20	30	50	65
Max. input length motor shaft	L <sub>7</sub>		27	27	42,5	56	57
Distance to center of screw	L <sub>8</sub>		5	5,5	7	9	9
Distance clamping ring - housing	L <sub>13</sub>		11,5	15,5	18	26	25,5
Square housing 1-stage	SQ <sub>1</sub>		45	62	90	122	140
Square housing 2-stage	SQ <sub>1</sub>		45	62	90	122	120
Feather key width	B <sub>1</sub>	h9	4	5	6	10	12
Min. mounting thread x depth	G <sub>1</sub>	4 x	M4 x 7	M5 x 10	M6 x 12	M8 x 12	M10 x 20
Min. mounting thread x depth	G <sub>2</sub>	4 x	M4 x 7	M5 x 10	M6 x 12	M6 x 12	M8 x 12
Min. mounting thread x depth	G <sub>3</sub>		M4 x 7	M5 x 11	M6 x 16	M12 x 24	M12 x 24
Angle in °	W <sub>1</sub>		45	45	45	45	45
x times angle in °	W <sub>2</sub>		4 x 90	4x 90	4x 90	4 x 90	4 x 90
Angle in °	W <sub>3</sub>		30°	30°	30°	60°	30°
x times angle in °	W <sub>4</sub>		4 x 90	4x 90	4x 90	4 x 90	4 x 90

Find more information regarding flanges and reduction sleeves for all common motor types on pages 48-50.

Planetary gears GSA • High-End range

			GSA050	GSA070	GSA090	GSA120	GSA160	Stage	
Service lifetime*1	t <sub>l</sub>	h	30000						
Nominal input speed	n <sub>1</sub>	min <sup>-1</sup>	4000	4000	4000	4000	3000		
Max. input speed	n <sub>1</sub> max.	min <sup>-1</sup>	8000	8000	8000	8000	6000		
Standard backlash	j <sub>1</sub>	arcmin	<= 3 (opt. <=1)					1	
			<= 5 (opt. <=3)					2	
Noise level*2	Q <sub>g</sub>	dB (A)	<=58	<=58	<=60	<=63	<=65	1	
			<=60	<=60	<=63	<=63	<=65	2	
Efficiency	η	%	>=97					1	
			>=94					2	
Protection class			IP65						
Torsional rigidity	c <sub>1</sub>	Nm/arcmin	3	6	15	27	60		
Max. radial force*3	F <sub>2r</sub>	N	620	1040	4210	8800	9450		
Max. axial force*3	F <sub>2a</sub>	N	310	520	2100	4400	4725		
Operating temperature	T <sub>B</sub>	°C	-25°C - +90°C						
Lubrication			Synthetic grease (lifetime-lubricated)						
Weight with flange*4	mg	kg	0,60	1,40	2,80	6,70	9,84	1	
			1,05	2,20	4,48	9,84	13,25	2	
Mounting position			Any						
Output torques			GSA050	GSA070	GSA090	GSA120	GSA160	Ratio	Stage
Nominal output torque*5	T <sub>2B</sub>	Nm	18	57	n.v.	n.v.	656	3	1
			16	50	153	218	583	4	1
			15	47	163	350	649	5	1
			14	43	149	324	602	7	1
			13	42	143	309	576	10	1
			18	57	n.v.	n.v.	656	15	2
			16	50	132	280	583	20	2
			15	47	166	311	649	25	2
			14	43	n.v.	n.v.	612	30	2
			14	43	134	289	602	35	2
			13	41	129	278	581	40	2
			15	47	145	311	649	50	2
			14	43	134	289	602	70	2
			13	42	127	275	576	100	2
Max. acceleration torque*6	T <sub>2N</sub>	Nm	32	103	n.v.	n.v.	1181	3	1
			29	90	275	392	1049	4	1
			27	85	293	630	1168	5	1
			25	77	268	583	1084	7	1
			23	76	257	556	1037	10	1
			32	103	n.v.	n.v.	1181	15	2
			29	90	238	504	1049	20	2
			27	85	299	560	1168	25	2
			25	77	n.v.	n.v.	1102	30	2
			25	77	241	520	1084	35	2
			23	74	232	500	1046	40	2
			27	85	261	560	1168	50	2
			25	77	241	520	1084	70	2
			23	76	229	495	1037	100	2
Emergency stop torque*7	T <sub>2Not</sub>	Nm	54	171	n.v.	n.v.	1968	3	1
			48	150	459	654	1749	4	1
			45	141	489	1050	1947	5	1
			42	129	447	972	1806	7	1
			39	126	429	927	1728	10	1
			54	171	n.v.	n.v.	1968	15	2
			48	150	396	840	1749	20	2
			45	141	498	933	1947	25	2
			42	129	n.v.	n.v.	1836	30	2
			42	129	402	867	1806	35	2
			39	123	387	834	1743	40	2
			45	141	435	933	1947	50	2
			42	129	402	867	1806	70	2
			39	126	381	825	1728	100	2

Mass moment of inertia			GSA050	GSA070	GSA090	GSA120	GSA160	Ratio	Stage
Mass moment of inertia <sup>*8</sup>	J <sub>i</sub>	kgcm <sup>2</sup>	0,03	0,15	n.v.	n.v.	9,21	3	1
			0,03	0,15	0,51	2,80	7,54	4	1
			0,03	0,13	0,45	2,71	7,42	5	1
			0,03	0,13	0,42	2,54	7,14	7	1
			0,03	0,13	0,42	2,51	7,03	10	1
			0,03	0,13	n.v.	n.v.	2,63	15	2
			0,03	0,13	0,13	0,47	2,63	20	2
			0,03	0,13	0,13	0,47	2,63	25	2
			0,03	0,13	n.v.	n.v.	2,43	30	2
			0,03	0,13	0,13	0,47	2,43	35	2
			0,03	0,13	0,13	0,47	2,43	40	2
			0,03	0,13	0,13	0,44	2,43	50	2
			0,03	0,13	0,13	0,44	2,39	70	2
0,03	0,13	0,13	0,44	2,39	100	2			

\*1 Load factor  $K_A=1$ ,  $n_2=100$  rpm ,at room temperature  $T=20^\circ\text{C}$  in new condition

\*2 Sound pressure level at 1m distance, measured for an input speed of 3000 rpm without load

\*3 On the center of the output shaft

\*4 Deviation of up to 10 % possible

\*5 Service life: 30,000 h,  $n_2=100$  rpm

\*6 Max 1000 cycles per hour. Acceleration torque proportion < 5% of the total operation time

\*7 Max 1000 cycles over the gear service life

\*8 Related to the input shaft

# Planetary gears GSB

Low-backlash high-end gears set new standards in torque.

Our GSB line stands for high performance in combination with low backlash and high precision. Helical gears ensure a minimum noise level and smooth running. The GSB line aligns economic efficiency with flexibility and is your perfect fit for a multitude of applications.

## You benefit from:

- Low backlash for high precision, standard as low as  $\leq 3$  arcmin, optional as low as  $\leq 1$  arcmin
- High torque level
- Best corrosion protection also for output side
- Low noise level up to  $< 56$  dB (A)
- Long product lifetime up to 30,000 h
- High torsional rigidity

### Precision ground helical gearing

Maximum precision and smoothness as well as minimization of operating noises.



### Full needle bearing

Torques that beat the competition for units of the same size.



### One-piece housing

High gearbox rigidity and absorption of high radial and axial loads.

## Typical application example



### IML robot

In the in-mould labelling process (IML), pre-cut plastic films are inserted into an injection mould using a handling device. By applying a vacuum or static charge, the labels are fixed and then back-injected with plastic. The IML robots, which are equipped with a GSB065, handle the exact label loading of the moulds. IML robots are generally of modular design - the high positioning accuracy, fast availability and excellent price/performance ratio were crucial factors in the decision in favor of the GSB series.

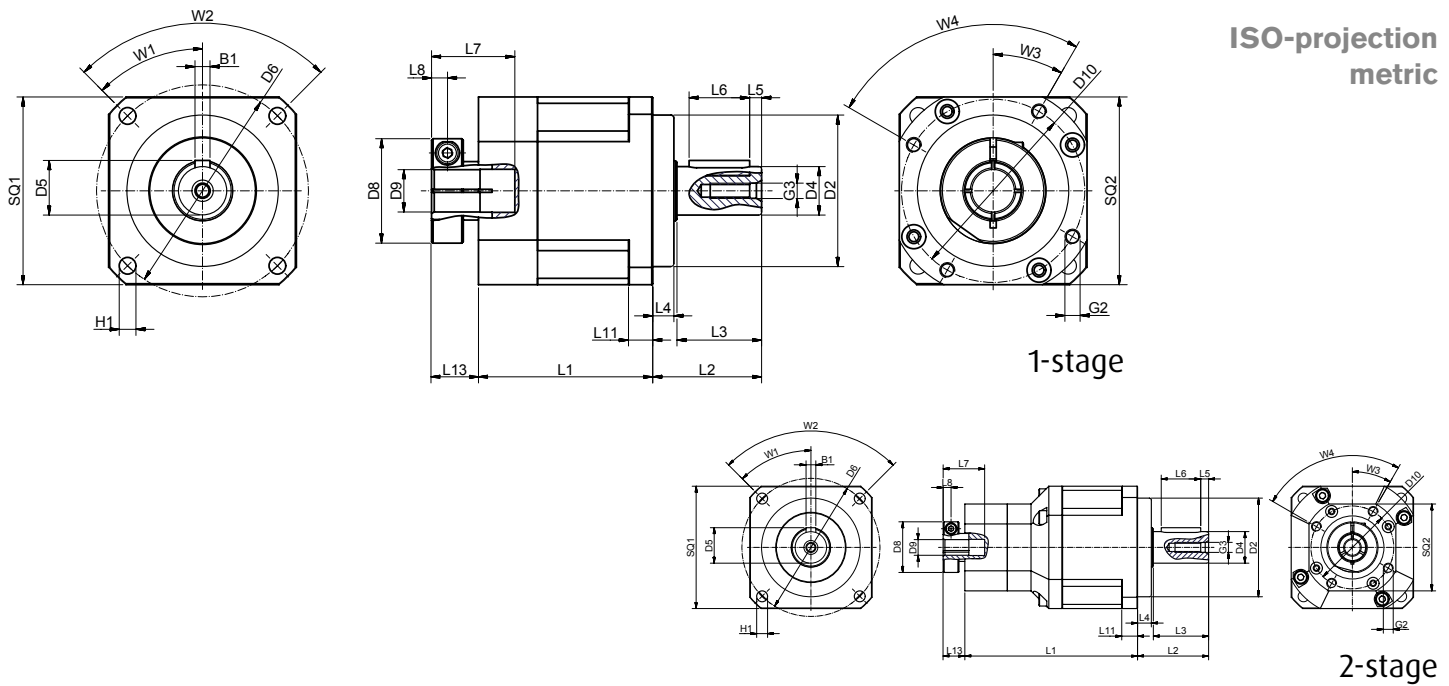
ISO-projection  
metric

## Planetary gears GSB • Dimensions

			Stage	GSB044	GSB062	GSB090	GSB120	GSB142	GSB180
Centering diameter output	$D_2$	h7		35	50	80	110	130	160
Output shaft diameter	$D_4$	h6		13	16	22	32	40	55
Shaft height including feather key	$D_5$			15	18	24.5	35	43	59
Hole circle diameter output	$D_6$			50	70	100	130	165	215
Clamping system diameter	$D_8$		1	27	40	49	67	80	107
			2	27	27	40	49	67	80
Max. motor shaft diameter	$D_9$	F7	1	11	19	24	28	35	55
			2	11	11	19	24	28	35
Hole circle diameter input	$D_{10}$		1	42	60.5	90	120	145	186
			2	42	42	60.5	90	120	145
Housing length	$L_1$		1	53	65.5	90	104.5	133	172
			2	79	87.5	111	149.5	171	217
Shaft length output	$L_2$			26	36	48	65	92	106
Shaft length from shoulder	$L_3$			20	28	36	50	74	82
Centering depth output	$L_4$			5	7	10	12	15	20
Distance from shaft end	$L_5$			2.5	4	3	5	5	6
Feather key length	$L_6$			15	20	30	40	65	70
Max. input length motor shaft	$L_7$		1	21	27.5	50	57	74.5	103
			2	21	21	27.5	50	57	74.5
Distance to center of screw	$L_8$		1	4.5	6	7	9	10.5	11
			2	4.5	4.5	6	7	9	10.5
Flange thickness output	$L_{11}$			5	8	10	12	15	16
Distance clamping ring - housing	$L_{13}$		1	11	15.5	17.5	25.5	25.5	34
			2	11	11	15.5	17.5	25.5	25.5
Square housing output	$SQ_1$			44	62	90	120	142	180
Square housing input	$SQ_2$		1	44	62	90	120	142	180
			2	44	44	62	90	120	142
Feather key width	$B_1$	h9		5	5	6	10	12	16
Min. mounting thread x depth	$G_2$	4 x	1	M4 x 8	M5 x 11	M6 x 12	M8 x 16	M10 x 20	M12 x 24
			2	M4 x 8	M4 x 8	M5 x 11	M6 x 12	M8 x 16	M10 x 20
Min. mounting thread x depth	$G_3$			M4 x 11	M5 x 14	M8 x 20	M10 x 23	M12 x 28	M14 x 32
Hole bore	$H_1$	4 x		4.5	5.5	6.8	9	11	13
Angle in °	$W_1$			45	45	45	45	45	45
x times angle in °	$W_2$			4 x 90	4 x 90	4 x 90	4 x 90	4 x 90	4 x 90
Angle in °	$W_3$			30	30	30	30	30	30
x times angle in °	$W_4$			4 x 90	4 x 90	4 x 90	4 x 90	4 x 90	4 x 90

Find more information regarding flanges and reduction sleeves for all common motor types on pages 48-50.

Planetary gears GSB • High-End range

			GSB044	GSB062	GSB090	GSB120	GSB142	GSB180	Stage
Service lifetime* <sup>1</sup>	$t_L$	h	30000						
Nominal input speed	$n_1$	rpm	5000	5000	4000	4000	3000	3000	
Max. input speed	$n_{1max}$	rpm	10000	10000	8000	8000	6000	6000	
Standard backlash	$j_t$	arcmin	<= 3 (opt. <= 1)						1
			<= 5 (opt. <= 3)						2
Noise level* <sup>2</sup>	$Q_g$	dB (A)	<= 56	<= 58	<= 60	<= 63	<= 65	<= 67	
Efficiency	$\eta$	%	>= 97						1
			>= 94						2
Protection class			IP65						
Torsional rigidity	$C_t$	Nm/arcmin	3	7	14	27	60	145	
Max. radial force* <sup>3</sup>	$F_{2r}$	N	780	1530	3250	6800	9400	15600	
Max. axial force* <sup>3</sup>	$F_{2a}$	N	390	765	1625	3700	4700	7800	
Operating temperature	$T_B$	°C	-25°C - +90°C						
Lubrication			Synthetic grease (lifetime-lubricated)						
Weight with flange* <sup>4</sup>	$m_g$	kg	0.6	1.28	3.6	8	14.3	28.3	1
			0.6	1.73	4.6	9.42	17.2	34.1	2
Mounting position			Any						

Output torques			GSB044	GSB062	GSB090	GSB120	GSB142	GSB180	Ratio	Stage
Nominal output torque* <sup>5</sup>	$T_{2N}$	Nm	20	62	173	352	656	1266	3	1
			17	54	153	315	583	1122	4	1
			17	50	168	350	649	1248	5	1
			16	47	156	324	602	1163	7	1
			14	45	150	313	581	1124	8	1
			15	45	148	309	576	1112	10	1
			20	62	173	352	656	1266	15	2
			17	54	153	315	583	1122	20	2
			17	50	168	350	649	1248	25	2
			16	47	159	327	612	1174	30	2
			16	47	156	324	602	1163	35	2
			17	50	168	350	649	1248	50	2
			16	47	156	327	612	1174	60	2
			15	45	150	324	602	1163	70	2
15	45	150	313	581	1124	80	2			
15	45	148	309	576	1112	100	2			

Max. acceleration torque* <sup>6</sup>	$T_{2B}$	Nm	36	112	311	634	1181	2279	3	1
			31	97	275	567	1049	2020	4	1
			31	90	302	630	1168	2246	5	1
			29	85	281	583	1084	2093	7	1
			25	81	270	563	1046	2023	8	1
			27	81	266	556	1037	2002	10	1
			36	112	311	634	1181	2279	15	2
			31	96	275	567	1049	2020	20	2
			31	90	302	630	1168	2246	25	2
			29	85	286	589	1102	2113	30	2
			29	85	281	583	1084	2093	35	2
			29	90	302	630	1168	2246	50	2
			29	85	281	588	1102	2113	60	2
			27	81	270	583	1084	2093	70	2
26	81	270	563	1045	2022	80	2			
27	81	266	556	1037	2002	100	2			

Emergency stop torque* <sup>7</sup>	$T_{2Not}$	Nm	60	186	519	1056	1968	3798	3	1
			51	162	459	945	1749	3366	4	1
			51	150	504	1050	1947	3744	5	1
			48	141	468	972	1806	3489	7	1
			42	135	450	939	1743	3372	8	1
			45	135	444	927	1728	3336	10	1
			60	186	519	1056	1968	3798	15	2
			51	162	459	945	1749	3366	20	2
			51	150	504	1050	1947	3744	25	2
			48	141	477	981	1836	3522	30	2
			48	141	468	972	1806	3489	35	2
			48	150	504	1050	1947	3744	50	2
			48	141	468	980	1836	3522	60	2
			45	135	450	972	1806	3489	70	2
44	135	450	939	1742	3371	80	2			
45	135	444	927	1728	3336	100	2			

Mass moment of inertia			GSB044	GSB062	GSB090	GSB120	GSB142	GSB180	Ratio	Stage
Mass moment of inertia <sup>*8</sup>	J <sub>1</sub>	kgcm <sup>2</sup>	0.03	0.16	0.61	3.25	9.21	28.98	3	1
			0.03	0.14	0.48	2.74	7.54	23.67	4	1
			0.03	0.13	0.47	2.71	7.42	23.29	5	1
			0.03	0.13	0.45	2.62	7.14	22.48	7	1
			0.03	0.13	0.44	2.58	7.07	22.59	8	1
			0.03	0.13	0.44	2.57	7.03	22.51	10	1
			0.03	0.03	0.14	0.46	2.63	7.30	15	2
			0.03	0.03	0.14	0.46	2.63	7.30	20	2
			0.03	0.03	0.14	0.46	2.63	7.10	25	2
			0.03	0.03	0.14	0.46	2.43	7.10	30	2
			0.03	0.03	0.14	0.44	2.43	7.10	35	2
			0.03	0.03	0.14	0.44	2.43	6.92	50	2
			0.03	0.03	0.14	0.43	2.39	6.72	60	2
			0.03	0.03	0.14	0.43	2.39	6.72	70	2
			0.03	0.03	0.14	0.43	2.39	6.72	80	2
0.03	0.03	0.14	0.40	2.39	6.72	100	2			

\*1 Load factor  $K_A=1$ ,  $n_2=100$  rpm, at room temperature  $T=20^\circ\text{C}$  in new condition

\*2 Sound pressure level at 1m distance, measured for an input speed of 3000 rpm without load

\*3 On the center of the output shaft

\*4 Deviation of up to 10 % possible

\*5 Service life: 30,000 h,  $n_2=100$  rpm

\*6 Max 1000 cycles per hour. Acceleration torque proportion < 5% of the total operation time

\*7 Max 1000 cycles over the gear service life

\*8 Related to the input shaft

# Planetary gears GSF

The low-noise high-end gear with high torsional rigidity.

The precision planetary gear units of the GSF series with ground helical gearing and preloaded double taper roller bearings ensure low-noise synchronism due to their immense load carrying capacity and rigidity even under high load conditions. The one-piece planet carrier and the integrated needle roller bearings enable the transmission of high torques. The additional shaft sealing ring ensures maximum protection against dust and splash water in accordance with protection class IP65.

## You benefit from:

- High torsional rigidity
- High radial and axial loads permissible
- Low backlash, standard as low as  $\leq 3$  arcmin, optional as low as  $\leq 1$  arcmin
- Low noise emission
- Protection class IP65

### One-piece planetary gear carrier

High gear rigidity and smooth running with simultaneous reduction of backlash.



### Double tapered roller bearings

High radial and axial loads.



### Integrated needle bearings

Low-noise synchronism with high load effect.

## Typical application example



### Axis drive for laser cutting machines

The GSF090 planetary gear, with a gear ratio of  $i=10$ , is used as a machine axis drive (x- and y-axis) in laser cutting machines. A servo motor and a rack and pinion complete the unit. Thanks to the nominal input speed of 4,000 rpm and the maximum input speed of 8,000 rpm, the gearbox is ideally suited for use in fast, dynamic laser cutting machines. Due to the high positioning accuracy and high dynamic driveability, the GSF line is the ideal choice for applications of this sort.

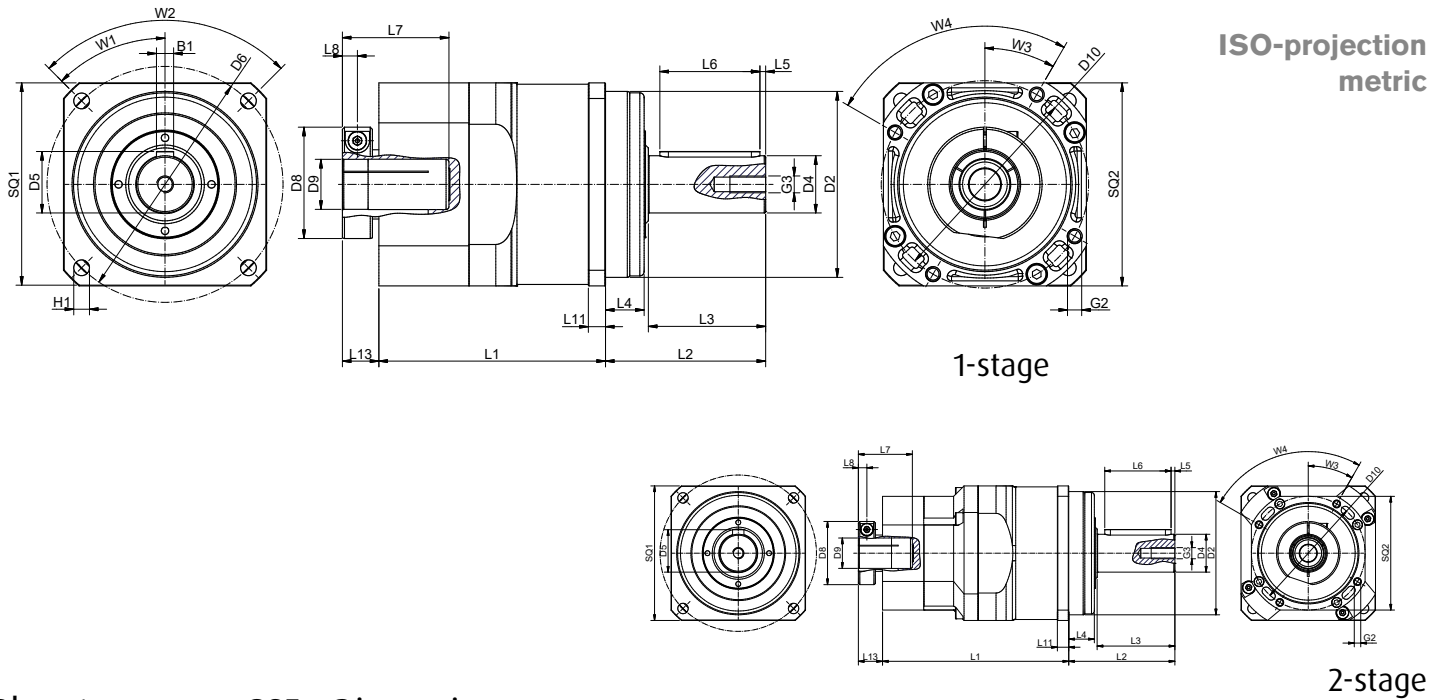

## Planetary gears GSF • Dimensions

			Stage	GSF062	GSF075	GSF100	GSF142	GSF180
Centering diameter output	D <sub>2</sub>	g6		60	70	90	130	160
Output shaft diameter	D <sub>4</sub>	k6		16	22	32	40	55
Shaft height including feather key	D <sub>5</sub>			18	24,5	35	43	59
Hole circle diameter output	D <sub>6</sub>			68	85	120	165	215
Clamping system diameter	D <sub>8</sub>		1	40	49	67	80	107
			2	27	40	49	67	80
Max. motor shaft diameter	D <sub>9</sub>	F7	1	19	24	28	38	55
			2	11	19	24	28	35
Hole circle diameter input	D <sub>10</sub>		1	60,5	90	120	145	186
			2	42	60,5	90	120	145
Housing length	L <sub>1</sub>		1	78	108,5	119	158,5	202,5
			2	100	129,3	163,5	196,5	247,5
Shaft length output	L <sub>2</sub>			48	56	88	112	112
Shaft length from shoulder	L <sub>3</sub>			28	36	58	82	82
Centering depth output	L <sub>4</sub>			18	18	27	27	26
Distance from shaft end	L <sub>5</sub>			4	2	4	4	6
Feather key length	L <sub>6</sub>			20	32	50	70	70
Max. input length motor shaft	L <sub>7</sub>		1	35,5	50	57	74,5	105
			2	21	35,5	50	57	74,5
Distance to center of screw	L <sub>8</sub>		1	6	7	9	10,5	11
			2	4,5	6	7	9	10,5
Flange thickness output	L <sub>11</sub>			6	7	10	12	15
Distance clamping ring - housing	L <sub>13</sub>		1	15,5	17,5	25,5	25,5	34
			2	11	15,5	17,5	25,5	25,5
Square housing output	SQ <sub>1</sub>			62	76	106	142	180
Square housing input	SQ <sub>2</sub>		1	62	90	120	142	180
			2	44	62	90	120	142
Feather key width	B <sub>1</sub>	h9		5	6	10	12	16
Min. mounting thread x depth	G <sub>2</sub>	4 x	1	M5 x 8	M6 x 10	M8 x 13	M10 x 16	M12 x 20
			2	M4 x 6	M5 x 8	M6 x 10	M8 x 13	M10 x 16
Min. mounting thread x depth	G <sub>3</sub>			M5 x 8	M8 x 13	M10 x 16	M12 x 20	M14 x 22
Hole bore	H <sub>1</sub>	4 x		5,5	6,8	9	11	13
Angle in °	W <sub>1</sub>			45°	45°	45°	45°	45°
x times angle in °	W <sub>2</sub>			4 x 90	4 x 90	4 x 90	4 x 90	4 x 90
Angle in °	W <sub>3</sub>			30°	30°	30°	30°	30°
x times angle in °	W <sub>4</sub>			4 x 90	4 x 90	4 x 90	4 x 90	4 x 90

Find more information regarding flanges and reduction sleeves for all common motor types on pages 48-50.

Planetary gears GSF • High-End range

			GSF062	GSF075	GSF100	GSF142	GSF180	Stage
Service lifetime* <sup>1</sup>	t <sub>l</sub>	h	30000					
Nominal input speed	n <sub>1</sub>	min <sup>-1</sup>	4000	4000	4000	4000	3000	
Max. input speed	n <sub>1</sub> max.	min <sup>-1</sup>	8000	8000	8000	8000	6000	
Standard backlash	j <sub>1</sub>	arcmin	<= 3 (opt. <=1)					1
			<= 5 (opt. <=3)					2
Noise level* <sup>2</sup>	O <sub>g</sub>	dB (A)	<=58	<=60	<=63	<=65	<=67	
Efficiency	η	%	>=97					1
			>=94					2
Protection class			IP65					
Torsional rigidity	c <sub>t</sub>	Nm/arcmin	8	15	27	60	150	
Max. radial force* <sup>3</sup>	F <sub>2r</sub>	N	2400	4300	8800	13000	17900	
Max. axial force* <sup>3</sup>	F <sub>2a</sub>	N	1950	3850	7600	10950	15200	
Operating temperature	T <sub>B</sub>	°C	-25°C - +90°C					
Lubrication			Synthetic grease (lifetime-lubricated)					
Weight with flange* <sup>4</sup>	mg	kg	1,70	4,50	8,30	16,70	34,30	1
			2,52	4,80	8,48	19,98	37,30	2
Mounting position			Any					

Output torques			GSF062	GSF075	GSF100	GSF142	GSF180	Ratio	Stage
Nominal output torque* <sup>5</sup>	T <sub>2B</sub>	Nm	62	173	227	656	1266	3	1
			54	153	218	583	1122	4	1
			50	163	350	649	1248	5	1
			47	149	324	602	1163	7	1
			45	143	309	576	1112	10	1
			62	149	313	656	1266	15	2
			54	132	280	583	1122	20	2
			50	166	311	649	1248	25	2
			47	137	292	612	1174	30	2
			47	134	289	602	1163	35	2
			45	129	278	581	1124	40	2
			50	145	311	649	1248	50	2
			47	134	289	602	1163	70	2
			45	127	275	576	1112	100	2
Max. acceleration torque* <sup>6</sup>	T <sub>2N</sub>	Nm	112	311	409	1181	2279	3	1
			97	275	392	1049	2020	4	1
			90	293	630	1168	2246	5	1
			85	268	583	1084	2093	7	1
			81	257	556	1037	2002	10	1
			112	268	563	1181	2279	15	2
			97	238	504	1049	2020	20	2
			90	299	560	1168	2246	25	2
			85	247	526	1102	2113	30	2
			85	241	520	1084	2093	35	2
			81	232	500	1046	2023	40	2
			90	261	560	1168	2246	50	2
			85	241	520	1084	2093	70	2
			81	229	495	1037	2002	100	2
Emergency stop torque* <sup>7</sup>	T <sub>2Not</sub>	Nm	186	519	681	1968	3798	3	1
			162	459	654	1749	3366	4	1
			150	489	1050	1947	3744	5	1
			141	447	972	1806	3489	7	1
			135	429	927	1728	3336	10	1
			186	447	939	1968	3798	15	2
			162	396	840	1749	3366	20	2
			150	498	933	1947	3744	25	2
			141	411	876	1836	3522	30	2
			141	402	867	1806	3489	35	2
			135	387	834	1743	3372	40	2
			150	435	933	1947	3744	50	2
			141	402	867	1806	3489	70	2
			135	381	825	1728	3336	100	2

Mass moment of inertia			GSF062	GSF075	GSF100	GSF142	GSF180	Ratio	Stage
Mass moment of inertia <sup>*8</sup>	J <sub>i</sub>	kgcm <sup>2</sup>	0,15	0,60	3,21	9,18	28,82	3	1
			0,14	0,51	2,80	7,51	23,56	4	1
			0,13	0,45	2,71	7,40	23,74	5	1
			0,13	0,42	2,54	7,15	22,40	7	1
			0,12	0,42	2,51	7,01	22,35	10	1
			0,03	0,13	0,47	2,63	7,30	15	2
			0,03	0,13	0,47	2,63	7,30	20	2
			0,03	0,13	0,47	2,43	7,10	25	2
			0,03	0,13	0,47	2,43	7,10	30	2
			0,03	0,13	0,47	2,43	7,10	35	2
			0,03	0,13	0,47	2,43	6,92	40	2
			0,03	0,13	0,44	2,43	6,92	50	2
			0,03	0,13	0,44	2,39	6,72	70	2
			0,03	0,13	0,44	2,39	6,72	100	2

\*1 Load factor  $K_A=1$ ,  $n_2=100$  rpm, at room temperature  $T=20^\circ\text{C}$  in new condition

\*2 Sound pressure level at 1m distance, measured for an input speed of 3000 rpm without load

\*3 On the center of the output shaft

\*4 Deviation of up to 10 % possible

\*5 Service life: 30,000 h,  $n_2=100$  rpm

\*6 Max 1000 cycles per hour. Acceleration torque proportion < 5% of the total operation time

\*7 Max 1000 cycles over the gear service life

\*8 Related to the input shaft

# Planetary gears GSD

High-end gearbox with the highest positioning precision for dynamic applications.

Its short design makes the GSD line the ideal high-end gearbox for space restricted applications. The flange output produces highest torsional rigidity. The low standard backlash of the GSD line makes it the perfect fit for highly dynamic applications where highest positioning and speed accuracy is required.

## You benefit from:

- Short construction
- Highest torsional rigidity
- High permissible radial and axial forces
- Low backlash, standard as low as  $\leq 3$  arcmin, optional as low as  $\leq 1$  arcmin
- Low noise level
- Protection class IP 65

### Output flange for robotics

Short design and stiff connection.



### Taper roller bearing

Accommodation of particularly high axial loads, optional for 90 mm diameter or higher.



### One-piece output flange / planetary carrier

High torsional rigidity and exact positioning precision.

## Typical application example



### Wheel hub drive for AGVs

Automated guided vehicles (AGV) distribute picked goods in roomy warehouse and trucking company halls. They usually work self-sufficiently. The AGVs are especially productive and economical if they are allowed to reach long travel distances and travel times without requiring repeated recharging of the energy storage units. This places special demands on construction and design. In particular, the vehicles and the installed components in it have to be lightweight and compact. Thanks to high bending rigidity, the high absorption of axial and radial loads and the compact design, the GSD line offers numerous advantages.

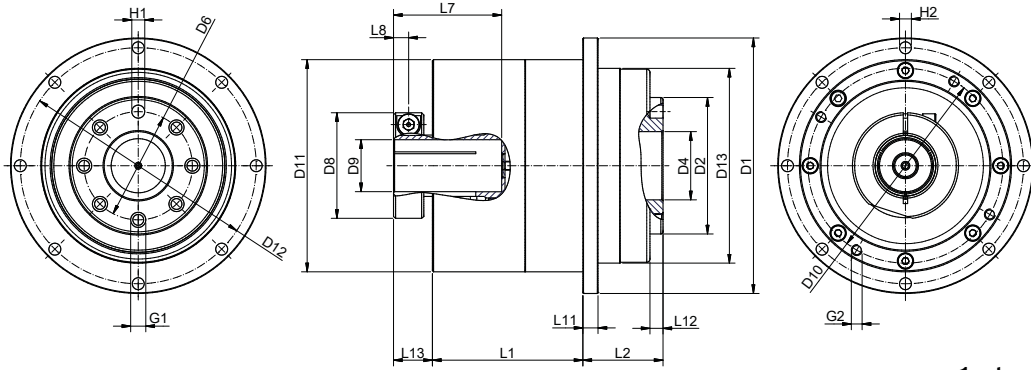
ISO-projection  
metric

1-stage

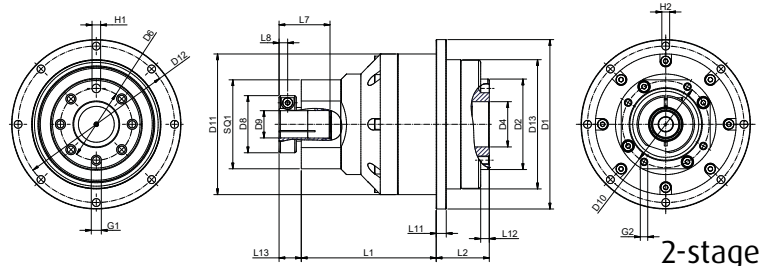

2-stage

## Planetary gears GSD • Dimensions

			Stage	GSD047	GSD064	GSD090	GSD110	GSD140
Housing diameter	$D_1$			72	86	118	146	179
Outer centering diameter output	$D_2$	h7		28	40	63	80	100
Inner centering diameter output	$D_4$	H7		12	20	31.5	40	50
Hole circle diameter output	$D_6$			20	31.5	50	63	80
Clamping system diameter	$D_8$		1	27	40	49	67	80
			2	27	29	40	49	67
Input hollow shaft diameter	$D_9$	F7	1	11	19	24	28	38
			2	11	14	19	24	35
Hole circle diameter input	$D_{10}$		1	42	60.5	90	120	143
			2	42	42	60.5	90	120
Housing diameter input	$D_{11}$	h7		59	70	98	125	156
Hole circle diameter (2) output	$D_{12}$			67	79	109	135	168
Output flange diameter	$D_{13}$	h7		47	64	90	110	140
Housing length	$L_1$		1	33.5	46.5	69.5	80.5	103
			2	61.5	68.5	94	125.5	161
Shaft length output	$L_2$			23.5	24.5	37	37	40
Max. input length motor shaft	$L_7$		1	27	28	49.5	57	100
			2	21	25.5	27.5	50	57
Distance to center of screw	$L_8$		1	4.5	6	7	9	10.5
			2	4.5	5	6	7	9
Flange thickness output	$L_{11}$			4	5	7	8	10
Flange length output	$L_{12}$			1.5	4	6	6	6
Distance clamping ring - housing	$L_{13}$		1	10	15.5	18	25.5	25.5
			2	10	11.5	15.5	18	25.5
Square housing	$SQ_1$			44	44	62	90	120
Min. mounting thread x depth	$G_1$			4 x M3 x 6.5	7 x M5 x 8	7 x M6 x 12	11 x M6 x 12	11 x M8 x 16
Min. mounting thread x depth	$G_2$		1	M4 x 8	M5 x 10	M5 x 10	M8 x 16	M8 x 16
			2	M4 x 8	M4 x 8	M5 x 10	M6 x 12	M8 x 16
Hole bore	$H_1$	H7		3 x 4	5 x 6	6 x 6	6 x 7	8 x 8
Hole bore	$H_2$			8 x 3.4	8 x 4.5	8 x 5.5	8 x 5.5	12 x 6.6

Find more information regarding flanges and reduction sleeves for all common motor types on pages 48-50.

Planetary gears GSD - High-End range

			GSD047	GSD064	GSD090	GSD110	GSD140	Stage
Service lifetime*1	$t_L$	h	30000					
Nominal input speed	$n_1$	rpm	5000	4500	4500	4000	3500	
Max. input speed	$n_{1max}$	rpm	10000	10000	8000	8000	6500	
Standard backlash	$j_t$	arcmin	<= 3 (opt. <=1)					1
			<= 5 (opt. <=3)					2
Noise level*2	$Q_g$	dB (A)	<= 56	<= 58	<= 60	<= 63	<= 65	
Efficiency	$\eta$	%	>= 97					1
			>= 94					2
Protection class			IP65					
Torsional rigidity	$C_t$	Nm/arcmin	6	14	30	86	155	
Max. radial force (ball bearing)*3	$F_{2r}$	N	1530	1890	6345	9540	10550	
Max. axial force (ball bearing)*3	$F_{2a}$	N	1020	1260	4230	6360	7035	
Max. radial force (tapered bearing)*3	$F_{2r}$	N	-	-	6345	9540	10550	
Max. axial force (tapered bearing)*3	$F_{2a}$	N	-	-	7330	11500	18600	
Operating temperature	$T_g$	°C	-25°C - +90°C					
Lubrication			Synthetic grease (lifetime-lubricated)					
Weight with flange*4	$m_g$	kg	0.7	1.4	4.2	7.4	13.9	1
			1	1.9	4.8	9.4	16.7	2
Mounting position			Any					

Output torques			GSD047	GSD064	GSD090	GSD110	GSD140	Ratio	Stage
Nominal output torque*5	$T_{2N}$	Nm	23	63	168	352	683	4	1
			21	53	163	350	649	5	1
			20	49	149	324	602	7	1
			17	45	143	309	576	10	1
			23	63	168	352	683	20	2
			21	53	163	350	649	25	2
			20	49	149	324	602	35	2
			23	63	168	352	683	40	2
			21	53	163	350	649	50	2
			20	49	149	324	602	70	2
			17	45	143	309	576	100	2

Max. acceleration torque*6	$T_{2B}$	Nm	41	113	302	634	1229	4	1
			38	95	293	630	1168	5	1
			36	89	268	583	1084	7	1
			31	81	257	556	1037	10	1
			41	113	302	634	1229	20	2
			38	95	293	630	1168	25	2
			36	88	268	583	1084	35	2
			41	113	302	634	1229	40	2
			38	95	293	630	1168	50	2
			36	88	268	583	1084	70	2
			31	81	257	556	1037	100	2

Emergency stop torque*7	$T_{2Not}$	Nm	69	189	504	1056	2049	4	1
			63	159	489	1050	1947	5	1
			60	148	447	972	1806	7	1
			51	135	429	927	1728	10	1
			69	189	504	1056	2049	20	2
			63	159	489	1050	1947	25	2
			60	147	447	972	1806	35	2
			69	189	504	1056	2049	40	2
			63	158	489	1050	1947	50	2
			60	147	447	972	1806	70	2
			51	135	429	927	1728	100	2

Mass moment of inertia			GSD047	GSD064	GSD090	GSD110	GSD140	Ratio	Stage
Mass moment of inertia <sup>*8</sup>	J <sub>i</sub>	kgcm <sup>2</sup>	0.03	0.13	0.47	2.75	7.46	4	1
			0.03	0.12	0.45	2.70	7.41	5	1
			0.03	0.12	0.45	2.64	7.12	7	1
			0.03	0.12	0.43	2.56	7.01	10	1
			0.03	0.03	0.15	0.45	2.7	20	2
			0.03	0.03	0.15	0.45	2.7	25	2
			0.03	0.03	0.15	0.45	2.7	35	2
			0.03	0.03	0.15	0.45	2.7	40	2
			0.03	0.03	0.14	0.40	2.6	50	2
			0.03	0.03	0.14	0.40	2.6	70	2
			0.03	0.03	0.14	0.40	2.6	100	2

\*1 Load factor  $K_A=1$ ,  $n_2=100$  rpm, at room temperature  $T=20^\circ\text{C}$  in new condition

\*2 Sound pressure level at 1 m distance, measured for an input speed of 3000 rpm without load

\*3 On the center of the output shaft

\*4 Deviation of up to 10 % possible

\*5 Service life: 30,000 h,  $n_2=100$  rpm

\*6 Max 1000 cycles per hour. Acceleration torque proportion < 5% of the total operation time

\*7 Max 1000 cycles over the gear service life

\*8 Related to the input shaft

# Planetary gears GSBL

Low-backlash high-end angular gearboxes - powerful performance in a small space.

Just like the GSB line, our GSBL line combines high performance with low backlash and high precision. Helical gears secure a minimum noise level and smooth running. The right angle shape makes the GSBL line the perfect match for all dynamic applications where space is limited.

## You benefit from:

- Right angle version for space restricted applications
- High torque level
- Up to ratio  $i = 200$  in 2-stage version
- Best corrosion protection also for output side
- Low noise level up to  $< 56$  dB (A)
- Long product life time up to 30,000 h

### Precision ground bevel gearbox

Maximum positioning accuracy and excellent quiet operating characteristics.



### Precision ground helical gearing

Maximum precision and smoothness as well as minimization of operating noises.

### One-piece planetary carrier

Highest positioning accuracy and high torsional rigidity.



## Typical application example



### Angle gearbox for rotary tables

The GSBL070 angular gearboxes with gear ratios  $i=5$  and  $i=10$  are often utilized in rotary tables due to their design, their exceptionally high performance and their high input speeds. The angle design enables optimum utilization of tight installation spaces. The high-end angular gearboxes of the GSBL line, for example, shine particularly in the case of rotary tables with high precision requirements.

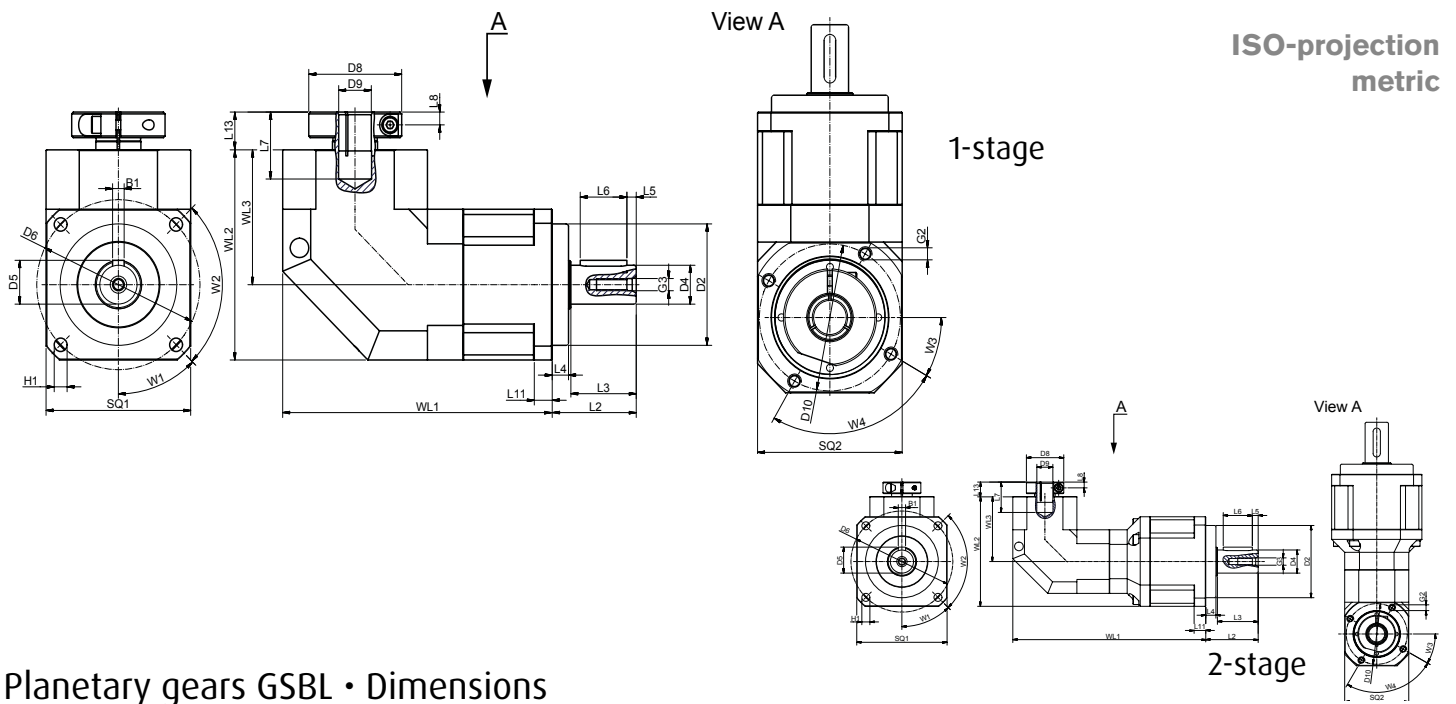

## Planetary gears GSBL • Dimensions

			Stage	GSBL044	GSBL062	GSBL090	GSBL120	GSBL142	GSBL180
Centering diameter output	$D_2$	h7		35	50	80	110	130	160
Output shaft diameter	$D_4$	h6		13	16	22	32	40	55
Shaft height including feather key	$D_5$			15	18	24.5	35	43	59
Hole circle diameter output	$D_6$			50	70	100	130	165	215
Clamping system diameter	$D_8$		1	27	40	49	67	80	107
			2	27	27	40	49	67	80
Max. motor shaft diameter	$D_9$	F7	1	11	19	24	28	35	55
			2	11	11	19	24	28	35
Hole circle diameter input	$D_{10}$		1	42	60.5	90	120	145	186
			2	42	42	60.5	90	120	145
Housing length (1)	$WL_1$		1	98	115.5	167.1	208	236.5	313.6
			2	124	132.5	161	226.6	274.5	320.5
Housing length (2)	$WL_2$		1	67	86.5	134	165.5	209.5	279
			2	67	67	86.5	134	165.5	209.5
Housing length (3)	$WL_3$		1	45	55.5	89	105.5	138.5	189.5
			2	45	45	55.5	89	105.5	138.5
Shaft length output	$L_2$			26	36	48	65	92	106
Shaft length from shoulder	$L_3$			20	28	36	50	74	82
Centering depth output	$L_4$			5	7	10	12	15	20
Distance from shaft end	$L_5$			2.5	4	3	5	5	6
Feather key length	$L_6$			15	20	30	40	65	70
Max. input length motor shaft	$L_7$		1	21	27.5	44	57	75	104.5
			2	21	21	27.5	44	57	75
Distance to center of screw	$L_8$		1	4.5	6	7	9	10.5	11
			2	4.5	4.5	6	7	9	10.5
Flange thickness output	$L_{11}$			5	8	10	12	15	16
Distance clamping ring - housing	$L_{13}$		1	10	15.5	17.5	25.5	25.5	33
			2	10	10	15.5	17.5	25.5	25.5
Square housing output	$SQ_1$			44	62	90	120	142	180
Square housing input	$SQ_2$		1	44	62	90	120	142	180
			2	44	44	62	90	120	142
Feather key width	$B_1$	h9		5	5	6	10	12	16
Min. mounting thread x depth	$G_2$	4 x	1	M4 x 8	M5 x 11	M6 x 12	M8 x 16	M10 x 20	M12 x 24
			2	M4 x 8	M4 x 8	M5 x 11	M6 x 12	M8 x 16	M10 x 20
Min. mounting thread x depth	$G_3$			M4 x 11	M5 x 14	M8 x 20	M10 x 23	M12 x 28	M14 x 32
Hole bore	$H_1$	4 x		4.5	5.5	6.8	9	11	13
Angle in °	$W_1$			45	45	45	45	45	45
x times angle in °	$W_2$			4 x 90	4 x 90	4 x 90	4 x 90	4 x 90	4 x 90
Angle in °	$W_3$			30	30	30	30	30	30
x times angle in °	$W_4$			4 x 90	4 x 90	4 x 90	4 x 90	4 x 90	4 x 90

Find more information regarding flanges and reduction sleeves for all common motor types on pages 48-50.

Planetary gears GSBL • High-End range

			GSBL044	GSBL062	GSBL090	GSBL120	GSBL142	GSBL180	Stage	
Service lifetime* <sup>1</sup>	$t_L$	h	30000							
Nominal input speed	$n_1$	rpm	5000	5000	4000	4000	3000	3000		
Max. input speed	$n_{1max}$	rpm	10000	10000	8000	8000	6000	6000		
Standard backlash	$j_t$	arcmin	<= 4 (opt. <=2)						1	
			<= 7 (opt. <=4)						2	
Noise level* <sup>2</sup>	$Q_g$	dB (A)	<= 65	<= 68	<= 70	<= 72	<= 74	<= 76		
Efficiency	$\eta$	%	>= 95						1	
			>= 92						2	
Protection class			IP65							
Torsional rigidity	$C_t$	Nm/arcmin	3	7	14	27	60	145		
Max. radial force* <sup>3</sup>	$F_{2r}$	N	780	1530	3250	6800	9400	15600		
Max. axial force* <sup>3</sup>	$F_{2a}$	N	390	765	1625	3700	4700	7800		
Operating temperature	$T_B$	°C	-25°C - +90°C							
Lubrication			Synthetic grease (lifetime-lubricated)							
Weight with flange* <sup>4</sup>	$m_g$	kg	1	2.2	6.6	13.2	22.3	50	1	
			1	2	5.5	12.5	23.2	44.4	2	
Mounting position			Any							
Output torques			GSBL044	GSBL062	GSBL090	GSBL120	GSBL142	GSBL180	Ratio	Stage
Nominal output torque* <sup>5</sup>	$T_{2N}$	Nm	20	62	173	352	656	1266	3	1
			17	54	153	315	583	1122	4	1
			17	50	168	350	649	1248	5	1
			16	47	156	324	602	1163	7	1
			15	45	148	309	576	1112	10	1
			15	45	150	313	581	1124	16	1
			15	45	148	309	576	1112	20	1
			17	50	168	350	649	1248	25	2
			16	47	159	327	612	1174	30	2
			17	50	168	350	649	1248	50	2
			16	47	156	324	602	1163	70	2
			15	45	148	309	576	1112	100	2
			16	47	156	324	602	1163	140	2
14	46	152	292	542	1043	180	2			
15	45	148	309	576	1112	200	2			
Max. acceleration torque* <sup>6</sup>	$T_{2B}$	Nm	36	112	311	634	1181	2279	3	1
			31	97	275	567	1049	2020	4	1
			31	90	302	630	1168	2246	5	1
			29	85	281	583	1084	2093	7	1
			27	81	266	556	1037	2002	10	1
			27	81	270	563	1046	2023	16	1
			27	81	266	556	1037	2002	20	1
			31	90	302	630	1168	2246	25	2
			29	85	286	589	1102	2113	30	2
			31	91	302	630	1168	2246	50	2
			29	85	281	583	1084	2093	70	2
			27	81	266	556	1037	2002	100	2
			29	85	281	583	1084	2093	140	2
25	83	274	526	976	1877	180	2			
27	81	266	556	1037	2002	200	2			
Emergency stop torque* <sup>7</sup>	$T_{2Not}$	Nm	60	186	519	1056	1968	3798	3	1
			51	162	459	945	1749	3366	4	1
			51	150	504	1050	1947	3744	5	1
			48	141	468	972	1806	3489	7	1
			45	135	444	927	1728	3336	10	1
			45	135	450	939	1743	3372	16	1
			45	135	444	927	1728	3336	20	1
			51	150	504	1050	1947	3744	25	2
			48	141	477	981	1836	3522	30	2
			51	151	504	1050	1947	3744	50	2
			48	141	468	972	1806	3489	70	2
			45	135	444	927	1728	3336	100	2
			48	141	468	972	1806	3489	140	2
			42	138	456	876	1626	3129	180	2
			45	135	444	927	1728	3336	200	2

Mass moment of inertia			GSBL044	GSBL062	GSBL090	GSBL120	GSBL142	GSBL180	Ratio	Stage
Mass moment of inertia <sup>*8</sup>	J <sub>1</sub>	kgcm <sup>2</sup>	0.09	0.36	2.28	6.85	23.50	68.2	3	1
			0.09	0.36	2.28	6.85	23.50	68.2	4	1
			0.09	0.36	2.28	6.85	23.50	68.2	5	1
			0.09	0.36	2.28	6.85	23.50	68.2	7	1
			0.09	0.36	2.28	6.85	23.50	68.2	10	1
			0.03	0.08	1.88	6.2	21.80	65.5	16	1
			0.03	0.08	1.88	6.2	21.80	65.5	20	1
			0.09	0.09	0.36	2.28	6.85	23.1	25	2
			0.09	0.09	0.36	2.28	6.85	23.1	30	2
			0.09	0.09	0.36	2.28	6.85	23.1	50	2
			0.09	0.09	0.36	2.28	6.85	23.1	70	2
			0.09	0.09	0.36	2.28	6.85	23.1	100	2
			0.03	0.03	0.10	1.88	6.20	21.2	140	2
			0.03	0.03	0.10	1.88	6.20	21.2	180	2
			0.03	0.03	0.10	1.88	6.20	21.2	200	2

\*1 Load factor  $K_A=1$ ,  $n_2=100$  rpm, at room temperature  $T=20^\circ\text{C}$  in new condition

\*2 Sound pressure level at 1 m distance, measured for an input speed of 3000 rpm without load

\*3 On the center of the output shaft

\*4 Deviation of up to 10 % possible

\*5 Service life: 30,000 h,  $n_2=100$  rpm

\*6 Max 1000 cycles per hour. Acceleration torque proportion < 5 % of the total operation time

\*7 Max 1000 cycles over the gear service life

\*8 Related to the input shaft

# Planetary gears GSN

The high-end economy gearbox distinguishes itself by excellent quiet operating characteristics and low noise emission.

The GSN line is the perfect match for applications where a backlash of 10 arcmin or better is required. Its helical gears secure a minimum noise level and a smooth running. The GSN line is used for various applications with regard to precision and efficiency.

## You benefit from:

- Low noise level due to ground helical gearing up to  $\leq 58$  dB (A)
- High power density
- Protection class IP 65
- High torsional rigidity
- Lifetime of 30,000 h
- Lifetime lubrication

### Full needle bearing

Torques that beat the competition for units of the same size.



### Precision ground helical gearing

Extremely quiet operating characteristics and minimization of operating noise.

### Shaft seal for protection class IP 65

Optimal protection against dust particles and splash water.



## Typical application example



### Height adjustment of cleaning systems

GSN series planetary gears are used in industrial surface cleaning systems of **Wandres GmbH micro-cleaning** for the automatic height adjustment of the cleaning unit. While the height adjustment was still done manually in older generations of the system, the planetary gear ensures an automated operation in combination with motor and inverter in new models. The cleaning systems are primarily used in the sheet metal and plate processing industry as well as in the printing, glass and automotive industries. The decision in favour of the GSN series was based in particular on its rapid availability and excellent price/performance ratio.

## GSN080 / 090

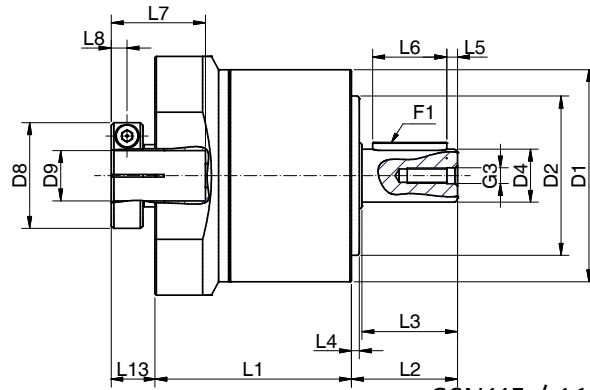
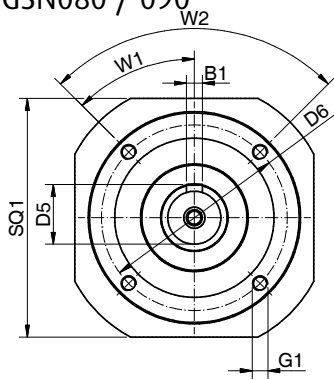
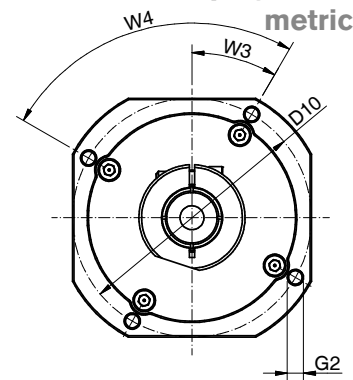
ISO-projection  
metric

## GSN050/060 / 070

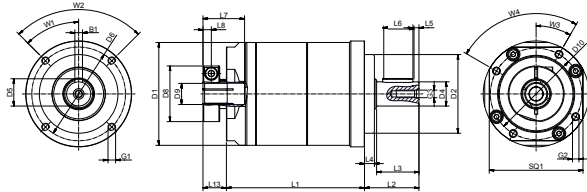

## GSN115 / 160

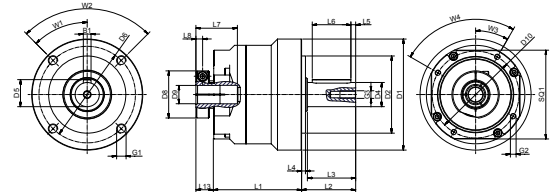

## Planetary gears GSN • Dimensions

			GSN050	GSN060	GSN070	GSN080	GSN090	GSN115	GSN160
Housing diameter	D <sub>1</sub>		50	60	70	80	90	115	160
Centering diameter output	D <sub>2</sub>	h7	35	40	52	60	68	80	130
Output shaft diameter	D <sub>4</sub>	h6	12	14	16	20	22	25	40
Shaft height including feather key	D <sub>5</sub>		13.5	16	18	22.5	24.5	28	43
Hole circle diameter output	D <sub>6</sub>		44	52	62	70	80	100	145
Clamping system diameter	D <sub>8</sub>		29	29	37	40	49	49	67
Max. motor shaft diameter	D <sub>9</sub>	F7	14	14	19	19	24	24	32
Hole circle diameter input	D <sub>10</sub>		40	42	60	90	90	90	145
Housing length 1-stage	L <sub>1</sub>		55	58	57.5	74	83	91	115
Housing length 2-stage	L <sub>1</sub>		81	84	91.3	109	-	134.5	175
Shaft length output	L <sub>2</sub>		21.5	34	36	40	46	56	88
Shaft length from shoulder	L <sub>3</sub>		20	30	28	36	36	50	78
Centering depth output	L <sub>4</sub>		4	3	6.5	3	8	4	8
Distance from shaft end	L <sub>5</sub>		2.5	2.5	4	4	2.5	5	5
Feather key length	L <sub>6</sub>		15	25	20	28	30	40	65
Max. input length motor shaft	L <sub>7</sub>		25	27.5	25	35.5	40	43	55
Distance to center of screw	L <sub>8</sub>		4.5	5	5.5	6	7	7	9
Distance clamping ring - housing	L <sub>13</sub>		11	11.5	15.5	16.5	17.5	18.5	35
Square housing	SQ <sub>1</sub>		-	44	62	90	90	92	120
Feather key width	B <sub>1</sub>	h9	4	5	5	6	6	8	12
Min. mounting thread x depth	G <sub>1</sub>	4 x	M4 x 8	M5 x 10	M5 x 10	M6 x 12	M6 x 12	M10 x 20	M12 x 24
Min. mounting thread x depth	G <sub>2</sub>	4 x	M4 x 8	M4 x 8	M5 x 10	M6 x 12	M6 x 12	M6 x 12	M8 x 20
Min. mounting thread x depth	G <sub>3</sub>		M4 x 11	M4 x 11	M5 x 11	M6 x 15	M8 x 16	M8 x 20	M8 x 16
Angle in °	W <sub>1</sub>		45	45	45	45	45	45	45
x times angle in °	W <sub>2</sub>		4 x 90	4 x 90	4 x 90	4 x 90	4 x 90	4 x 90	4 x 90
Angle in °	W <sub>3</sub>		30	30	30	30	30	30	30
x times angle in °	W <sub>4</sub>		4 x 90	4 x 90	4 x 90	4 x 90	4 x 90	4 x 90	4 x 90

Find more information regarding flanges and reduction sleeves for all common motor types on pages 48-50.

Planetary gears GSN • High-End Economy range

			GSN050	GSN060	GSN070	GSN080	GSN090	GSN115	GSN160	Stage
Service lifetime <sup>*1</sup>	t <sub>l</sub>	h	30000							
Nominal input speed	n <sub>1</sub>	rpm	4500	4500	4500	4000	4000	4000	4000	
Max. input speed	n <sub>1</sub> max.	rpm	8000	8000	8000	7000	7000	7000	7000	
Standard backlash	j <sub>1</sub>	arcmin	<=7							1
			<=10							2
Noise level <sup>12</sup>	O <sub>g</sub>	dB (A)	<=58		<=60	<=63	<=65			
Efficiency	η	%	>=97							1
			>=95							2
Protection class			IP65							
Torsional rigidity	c <sub>t</sub>	Nm/arcmin	3	4	5	12	13	14	60	
Max. radial force <sup>*3</sup>	F <sub>2r</sub>	N	725	1100	1770	2400	3150	3590	7800	
Max. axial force <sup>*3</sup>	F <sub>2a</sub>	N	392	515	890	1275	1575	1795	4650	
Operating temperature	T <sub>B</sub>	°C	-25°C - +90°C							
Lubrication			liquid grease (lifetime-lubricated)							
Weight with flange <sup>*4</sup>	mg	kg	0.73	0.99	1.25	2.1	3.5	4.98	13.25	1
			1.05	1.46	1.9	3.2	5.2	6.92	18.5	2
Mounting position			Any							

Output torques			GSN050	GSN060	GSN070	GSN080	GSN090	GSN115	GSN160	Ratio	Stage
Nominal output torque <sup>*5</sup>	T <sub>2B</sub>	Nm	18	29	57	118	153	182	688	3	1
			16	40	50	116	151	161	611	4	1
			15	42	47	113	147	176	680	5	1
			14	37	43	110	134	164	630	7	1
			13	26	42	105	129	155	604	10	1
			18	29	57	118	153	182	688	15	2
			16	40	50	116	151	161	611	20	2
			15	42	47	113	147	176	680	25	2
			14	29	43	118	153	182	641	30	2
			14	37	43	110	134	164	630	35	2
			13	40	41	116	151	161	608	40	2
			15	42	47	113	147	176	680	50	2
			14	37	43	110	134	164	630	70	2
			13	26	42	105	129	155	604	100	2
Max. acceleration torque <sup>*6</sup>	T <sub>2N</sub>	Nm	31	50	97	202	263	297	1125	3	1
			27	68	86	198	259	268	999	4	1
			25	72	81	194	252	288	1112	5	1
			23	63	74	189	230	268	1031	7	1
			22	45	72	180	221	254	988	10	1
			31	50	97	202	263	297	1125	15	2
			27	68	86	198	259	263	999	20	2
			25	72	81	194	252	288	1112	25	2
			23	50	74	202	263	297	1049	30	2
			23	63	74	189	230	268	1031	35	2
			22	68	70	198	259	263	995	40	2
			25	72	81	194	252	288	1112	50	2
			23	63	74	189	230	268	1031	70	2
			22	45	72	180	221	254	988	100	2
Emergency stop torque <sup>*7</sup>	T <sub>2Not</sub>	Nm	54	87	171	354	459	546	2064	3	1
			48	120	150	348	453	483	1833	4	1
			45	126	141	339	441	528	2040	5	1
			42	111	129	330	402	492	1890	7	1
			39	78	126	315	387	465	1812	10	1
			54	87	171	354	459	546	2064	15	2
			48	120	150	348	453	483	1833	20	2
			45	126	141	339	441	528	2040	25	2
			42	87	129	354	459	546	1923	30	2
			42	111	129	330	402	492	1890	35	2
			39	120	123	348	453	483	1824	40	2
			45	126	141	339	441	528	2040	50	2
			42	111	129	330	402	492	1890	70	2
			39	78	126	315	387	465	1812	100	2

Mass moment of inertia			GSN050	GSN060	GSN070	GSN080	GSN090	GSN115	GSN160	Ratio	Stage
Mass moment of inertia <sup>8</sup>	J <sub>i</sub>	kgcm <sup>2</sup>	0.030	0.06	0.15	0.48	0.55	0.60	9.21	3	1
			0.030	0.06	0.15	0.38	0.42	0.45	7.54	4	1
			0.030	0.06	0.13	0.38	0.42	0.45	7.42	5	1
			0.030	0.06	0.13	0.38	0.42	0.45	7.14	7	1
			0.030	0.06	0.13	0.35	0.42	0.41	7.03	10	1
			0.025	0.05	0.11	0.29	0.38	0.40	8.65	15	2
			0.025	0.05	0.11	0.29	0.38	0.40	7.08	20	2
			0.025	0.05	0.11	0.29	0.38	0.40	6.97	25	2
			0.025	0.05	0.11	0.29	0.38	0.40	8.65	30	2
			0.025	0.05	0.11	0.29	0.38	0.40	6.71	35	2
			0.025	0.05	0.11	0.29	0.38	0.40	7.08	40	2
			0.025	0.05	0.11	0.29	0.38	0.40	6.97	50	2
			0.025	0.05	0.11	0.29	0.38	0.40	6.71	70	2
0.025	0.05	0.11	0.26	0.32	0.38	6.61	100	2			

\*1 Load factor  $K_A=1$ ,  $n_2=100$  rpm, at room temperature  $T=20^\circ\text{C}$  in new condition

\*2 Sound pressure level at 1 m distance, measured for an input speed of 3000 rpm without load

\*3 On the center of the output shaft

\*4 Deviation of up to 10 % possible

\*5 Service life: 30,000 h,  $n_2=100$  rpm

\*6 Max 1000 cycles per hour. Acceleration torque proportion < 5% of the total operation time

\*7 Max 1000 cycles over the gear service life

\*8 Related to the input shaft

# Planetary gears GFE

The flexible high-end economy gearbox features impressively high torque.

Our GFE line is available in seven sizes ranging from 50 mm to 220 mm. Ground helical gears ensure a minimum noise level and smooth running. The GFE line stands for economic efficiency and fits perfectly for applications with high torques.

## You benefit from:

- Big housing sizes up to 220 mm
- Max. input speed up to 10,000 rpm
- 30,000 h lifetime
- Nominal output torques up to 1,562 Nm
- Protection class IP 65
- Lifetime lubrication



## Typical application example



## Height adjustment of operating tables

For height adjustment of OP tables, two aspects play an especially decisive role. Use in the direct vicinity of the patient means that high positioning accuracy and smoothness are indispensable. The planetary gears of the GFE line fulfill the noise minimization requirements through precision ground, helical cut gears.

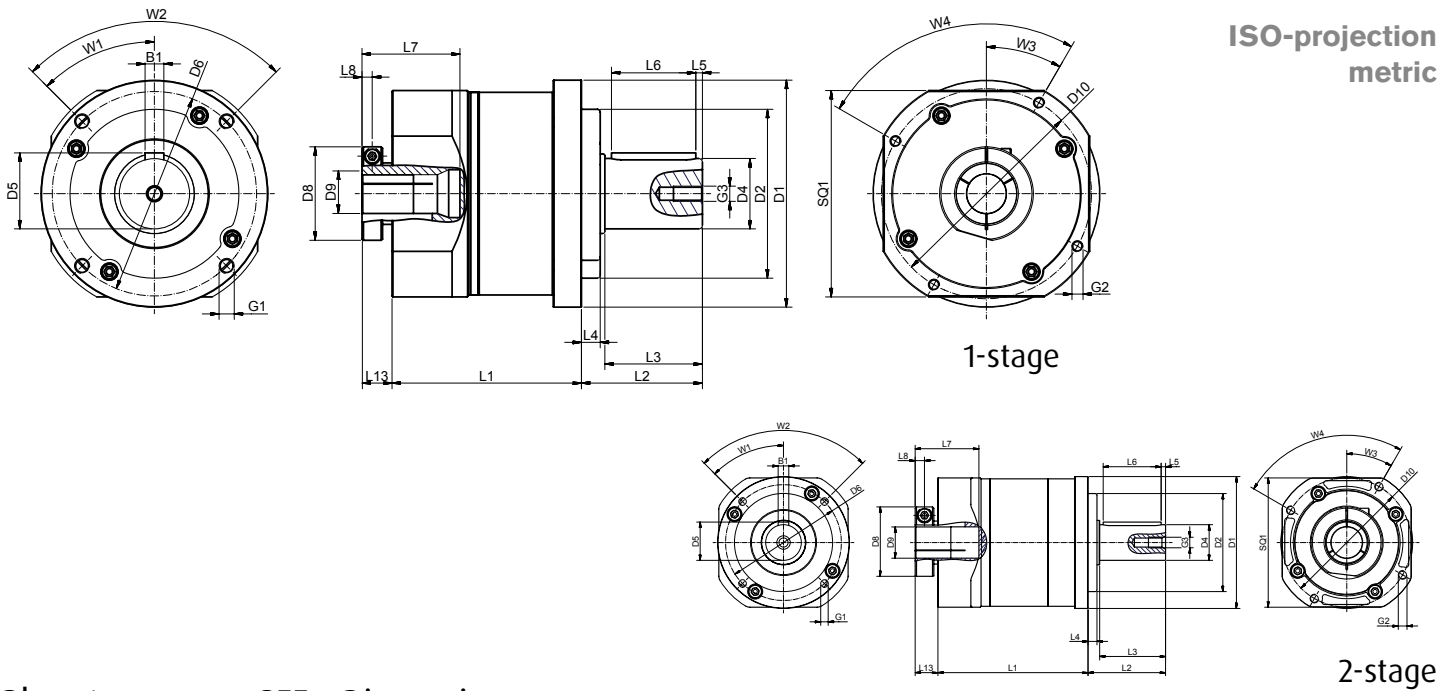
ISO-projection  
metric

## Planetary gears GFE • Dimensions

			GFE050	GFE070	GFE090	GFE120	GFE145	GFE180	GFE220
Housing diameter	D <sub>1</sub>		50	70	93	122	148	205	242
Centering diameter output	D <sub>2</sub>	h7	35	50	70	90	110	160	180
Output shaft diameter	D <sub>4</sub>	h6	13	16	22	32	40	55	75
Shaft height including feather key	D <sub>5</sub>		15	18	24.5	35	43	59	79.5
Hole circle diameter output	D <sub>6</sub>		42	60	80	105	130	184	218
Clamping system diameter	D <sub>8</sub>		27	40	49	67	80	100	107
Max. motor shaft diameter	D <sub>9</sub>	F7	11	19	24	28	38	48	55
Hole circle diameter input	D <sub>10</sub>		42	60	90	120	145	186	224
Housing length 1-stage	L <sub>1</sub>		59.5	85	100	132	168.5	173.5	202
Housing length 2-stage	L <sub>1</sub>		86	119	140	186	232.5	243	289
Shaft length output	L <sub>2</sub>		25	34	44	60	87	106	129
Shaft length from shoulder	L <sub>3</sub>		20	28	36	50	74	82	104
Centering depth output	L <sub>4</sub>		4	5	6	8	10	20	20
Distance from shaft end	L <sub>5</sub>		2.5	4	3	5	5	6	7
Feather key length	L <sub>6</sub>		15	20	30	40	65	70	90
Max. input length motor shaft	L <sub>7</sub>		21	27.5	42	53	71.5	102	114.5
Distance to center of screw	L <sub>8</sub>		4.5	6	7	9	10.5	11	11
Distance clamping ring - housing	L <sub>13</sub>		11	15.5	17.5	25.5	25.5	32.5	32.5
Square housing	SQ <sub>1</sub>		45	62	90	120	145	180	220
Feather key width	B <sub>1</sub>	h9	5	5	6	10	12	16	20
Min. mounting thread x depth	G <sub>1</sub>	4 x	M4 x 8	M5 x 10	M6 x 12	M8 x 16	M10 x 16	M12 x 22.5	M16 x 31
Min. mounting thread x depth	G <sub>2</sub>	4 x	M4 x 7	M5 x 10	M6 x 12	M8 x 16	M10 x 20	M12 x 24	M12 x 24
Min. mounting thread x depth	G <sub>3</sub>		M4 x 10	M5 x 13	M6 x 20	M10 x 23	M12 x 27	M14 x 33	M16 x 36
Angle in °	W <sub>1</sub>		45	45	45	45	45	45	45
x times angle in °	W <sub>2</sub>		4 x 90	4 x 90	4 x 90	4 x 90	4 x 90	4 x 90	4 x 90
Angle in °	W <sub>3</sub>		30	30	30	30	30	30	30
x times angle in °	W <sub>4</sub>		4 x 90	4 x 90	4 x 90	4 x 90	4 x 90	4 x 90	4 x 90

Find more information regarding flanges and reduction sleeves for all common motor types on pages 48-50.

Planetary gears GFE • High-End Economy range

			GFE050	GFE070	GFE090	GFE120	GFE145	GFE180	GFE220	Stage
Service lifetime <sup>*1</sup>	t <sub>l</sub>	h	30000							
Nominal input speed	n <sub>1</sub>	rpm	5000	4000	4000	4000	3000	2500	2000	
Max. input speed	n <sub>1</sub> max.	rpm	10000	7000	7000	7000	6000	4000	3000	
Standard backlash	j <sub>1</sub>	arcmin	<=7							1
			<=10							2
Noise level <sup>12</sup>	O <sub>g</sub>	dB (A)	<=62	<=62	<=65	<=68	<=70	<=70	<=70	
Efficiency	η	%	>=97							1
			>=94							2
Protection class			IP65							
Torsional rigidity	c <sub>t</sub>	Nm/arcmin	2.3	5	15	45	69	140	220	
Max. radial force <sup>*3</sup>	F <sub>2r</sub>	N	810	1900	3000	6500	9100	11150	35000	
Max. axial force <sup>*3</sup>	F <sub>2a</sub>	N	480	590	1900	3250	4900	5575	17500	
Operating temperature	T <sub>B</sub>	°C	-25°C - +90°C							
Lubrication			liquid grease (lifetime-lubricated)							
Weight with flange <sup>*4</sup>	mg	kg	0.63	1.57	3.22	8	16	33	54	1
			0.9	2.24	4.59	11.22	22.5	46.4	75	2
Mounting position			Any							

Output torques			GFE050	GFE070	GFE090	GFE120	GFE145	GFE180	GFE220	Ratio	Stage
Nominal output torque <sup>*5</sup>	T <sub>2B</sub>	Nm	19	55	138	295	530	1034	1562	3	1
			17	50	122	262	469	946	1430	4	1
			15	46	114	245	441	1018	1397	5	1
			14	43	108	229	410	869	1298	7	1
			13	41	101	218	392	836	1254	10	1
			19	55	138	295	530	1034	1562	15	2
			17	50	122	262	469	946	1430	20	2
			15	46	114	245	441	919	1397	25	2
			19	55	138	295	530	1034	1562	30	2
			14	43	108	229	410	869	1298	35	2
			17	50	122	262	470	946	1430	40	2
			15	46	114	245	442	919	1397	50	2
			14	44	108	229	410	869	1298	70	2
			13	41	101	218	393	836	1210	100	2
Max. acceleration torque <sup>*6</sup>	T <sub>2N</sub>	Nm	34	99	248	531	954	1861	2812	3	1
			30	89	220	471	843	1703	2574	4	1
			28	83	206	442	794	1832	2515	5	1
			26	77	194	412	739	1564	2336	7	1
			24	73	182	392	705	1505	2257	10	1
			34	99	248	531	954	1861	2812	15	2
			30	89	220	471	843	1703	2574	20	2
			28	83	206	442	794	1653	2515	25	2
			34	99	248	531	954	1861	2812	30	2
			26	77	194	412	739	1564	2336	35	2
			30	89	220	471	845	1703	2574	40	2
			28	83	206	442	796	1653	2515	50	2
			26	79	194	412	739	1564	2336	70	2
			24	73	182	392	707	1505	2178	100	2
Emergency stop torque <sup>*7</sup>	T <sub>2Not</sub>	Nm	56	165	413	884	1591	3102	4686	3	1
			50	149	366	785	1406	2838	4290	4	1
			46	139	343	736	1323	3053	4191	5	1
			43	129	323	686	1231	2607	3894	7	1
			40	122	304	653	1175	2508	3762	10	1
			56	165	413	884	1591	3102	4686	15	2
			50	149	366	785	1406	2838	4290	20	2
			46	139	343	736	1323	2756	4191	25	2
			56	165	413	884	1591	3102	4686	30	2
			43	129	323	686	1231	2607	3894	35	2
			50	149	366	785	1409	2838	4290	40	2
			46	139	343	736	1327	2756	4191	50	2
			43	132	323	686	1231	2607	3894	70	2
			40	122	304	653	1178	2508	3630	100	2

Mass moment of inertia			GFE050	GFE070	GFE090	GFE120	GFE145	GFE180	GFE220	Ratio	Stage
Mass moment of inertia <sup>8</sup>	J <sub>i</sub>	kgcm <sup>2</sup>	0.04	0.14	0.61	3.25	8.75	24.63	50.67	3	1
			0.04	0.11	0.47	2.74	6.84	20.12	46.21	4	1
			0.04	0.11	0.47	2.74	6.84	19.8	45.28	5	1
			0.04	0.11	0.44	2.58	6.78	19.21	43.32	7	1
			0.04	0.11	0.47	2.74	6.84	19.13	42.98	10	1
			0.04	0.14	0.61	3.25	8.75	24.63	50.67	15	2
			0.04	0.13	0.48	2.74	7.16	20.12	46.21	20	2
			0.04	0.11	0.47	2.74	6.84	19.8	45.28	25	2
			0.04	0.14	0.61	3.25	8.75	24.63	50.67	30	2
			0.04	0.11	0.44	2.58	6.78	19.21	43.32	35	2
			0.04	0.11	0.48	2.74	7.16	20.12	46.21	40	2
			0.04	0.11	0.47	2.74	6.84	19.8	45.28	50	2
			0.04	0.11	0.44	2.58	6.78	19.21	43.32	70	2
0.04	0.11	0.47	2.74	6.84	19.13	42.98	100	2			

\*1 Load factor  $K_A=1$ ,  $n_2=100$  rpm, at room temperature  $T=20^\circ\text{C}$  in new condition

\*2 Sound pressure level at 1 m distance, measured for an input speed of 3000 rpm without load

\*3 On the center of the output shaft

\*4 Deviation of up to 10 % possible

\*5 Service life: 30,000 h,  $n_2=100$  rpm

\*6 Max 1000 cycles per hour. Acceleration torque proportion < 5% of the total operation time

\*7 Max 1000 cycles over the gear service life

\*8 Related to the input shaft

# Custom engineered planetary gears.

Individually designed for your application.



## Planetary gears and more – your application is our priority.

### Project development

Based on your specifications, we develop the optimum technical and cost-effective solution for the defined application.

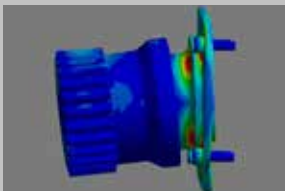

### Application expertise

We have already developed and produced countless drive solutions – from worm, spur or planetary gears to complex drive systems – for a variety of applications.



### Systems competence

You benefit from our experience gained from the technical implementation of drive solutions for many different industries.



“Your idea – our drive”: our drive solutions have set standards for numerous applications and sectors according to this motto. Our customers appreciate us as experienced development partners who deliver a technically and commercially convincing result. Many innovative special systems based on planetary gears have already been created in this way – for example our hub gearbox systems for the intralogistics sector. You benefit from our experience: Because no application is so special that we would not have the right solution – whether a complete custom engineered new development or an easy adaption of our standard planetary gears.

**Framo Morat – your engineering partner with systems competence:**

- Individual choice of material, diameter, mounting, tooth width, etc. for each planetary stage
- Perfect linkage at every interface
- Integration of the drive in your complete system, taking into account mechanics, electronics and control technology



**Hub gearbox systems**

Planetary gears with taper roller bearings are frequently used in applications in which high radial loads occur. With its longtime experience in gear and drive engineering, Framo Morat has developed a hub drive system based on a standard planetary gear. The custom design, which permits higher radial loads, reduces the total length of the gearbox by more than 40%. The use of standardized ball bearings contributes to cost-effectiveness. The wheel hub drive is based on a planetary gear with a 40 mm diameter and a gear ratio of 5:1. Taking account of the application-specific loads and requirements, as well as the desired gearbox ratios, almost all standard planetary gears can be used for such a drive system. The efficient and compact wheel hub drive is used in numerous intralogistics applications, for example in warehouse shuttle systems or automated guided vehicles (AGV).

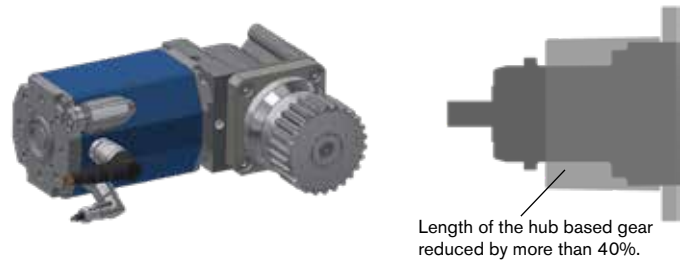

**Quality assurance**

We ensure reproducible results at the highest quality level by means of inline measurements and visual inspections.



**Depth of production**

Turning, milling, gear cutting, squaring up, countersinking, hardening, grinding – we produce all components, from the individual gearwheel to the complete drive, in our own workshops.



**Serial production**

After successful quality inspections, we mount the components in separate assembly cells – ready for delivery.



# Customer-specific planetary gears.

Individualized design for your requirements.

There are many ways to influence the technical and economical properties of a gearbox. It is here that an old engineering rule of thumb applies: "Not as good as possible, but as good as is necessary!" At Framo Morat, we have been working in accordance with this motto for decades when it comes to designing and developing individual drive solutions.

Gear types, materials, bearings, lubricants and, not least, the installation dimensions are essential factors with which the performance data of the planetary gears can be adapted to the respective application requirement profiles.

The options given here serve as an overview of the different adjusting screws and their effects.

In the design of your customized planetary gear, you will benefit from our expertise in gear technology, our know-how in combination with tried-and-tested materials, as well as our decades-long experience in developing customer-specific drive solutions. We would be glad to speak with you. Contact us directly with any wishes or requests.

**Phone +49 7657 88-173 ▪ e-mail [pe@framo-morat.com](mailto:pe@framo-morat.com)**

## Gearbox installation dimensions, levels, and gear ratios

### Common gear diameters to 220 mm

- + Field-tested gear teeth

### Alternative sizes to 250 mm

- + Optimal installation space

### Gear stages: 1-stage, 2-stage, 3-stage, 4-stage

Common gear ratios per planetary carrier 3:1 to 10:1  
any overall gear ratio is possible

## Planetary gear bearing

### Pin cage

- + Standardized components

### Fully acicular planetary gear bearing

- + Higher torques can be transmitted
- + Improved gear service life

### Sliding bearing

- + Simplified gear structure

## Input shaft

### Hollow shaft with optional reduction sleeve

### Hollow shaft fitted to motor shaft

- + Omission of reduction sleeve

### Direct connection to motor

- + Omission of hollow input shaft
- + Improved operational behavior

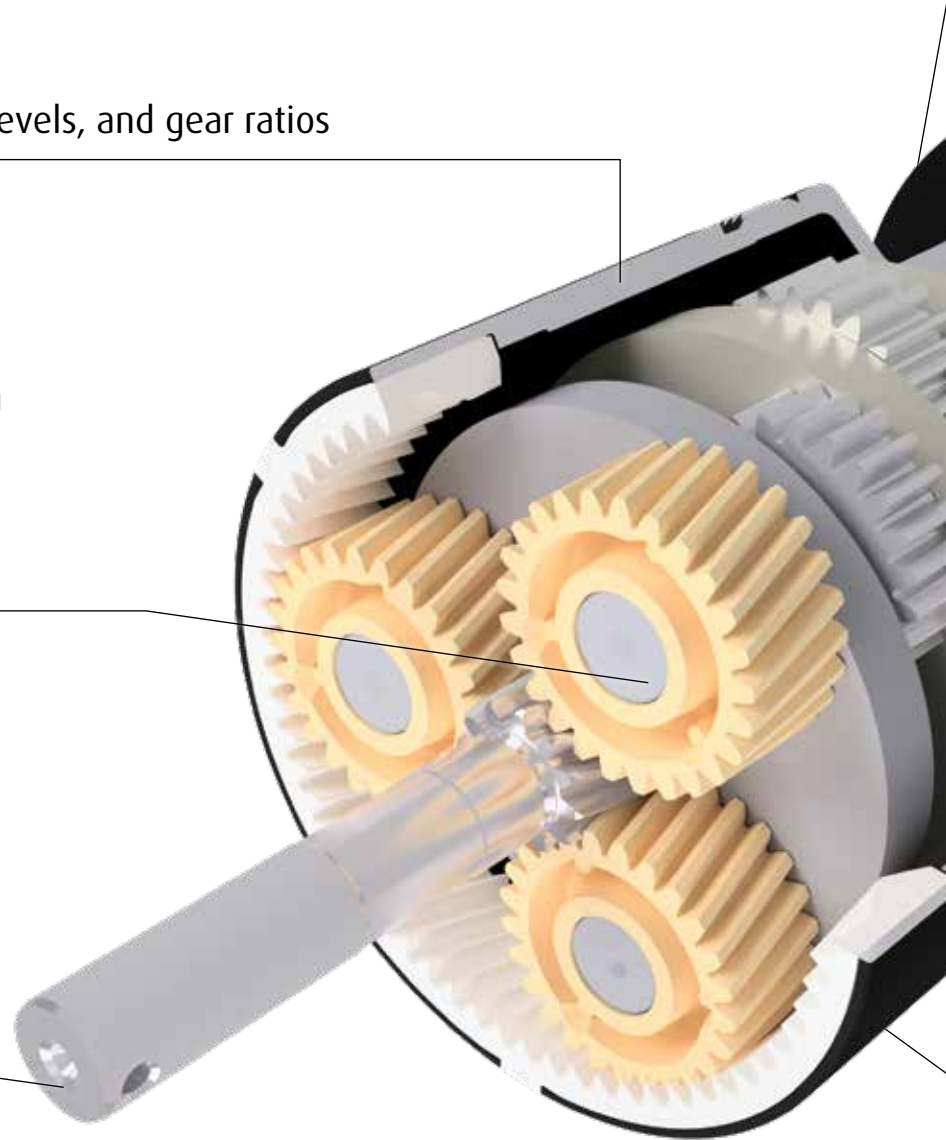

## Gearing

### Spur gearing

+ Cost-effective use for moderate noise emission and operational behavior requirements

### Precision ground spur gearing

+ Optimized operational noise  
+ Improved operational behavior

### Helical gearing

+ Higher torque transfer  
+ Improved operational behavior

## Output flange

### B14 flange connection

### B5 flange connection

### Customized flange

## Output shaft

### Output shaft with feather key groove

### Output shaft without feather key groove

+ Clamp with lower circumferential backlash possible

### Output shaft as hollow shaft

+ Improved connection of shafts as a counterpart

### Output shaft as robot flange

+ Optimized torsional rigidity

### Output using internal geared wheel

+ More compact design

## Bearing on the input and output sides

### Deep grooved ball bearing

+ Cost-effective and sufficient for moderate loads

### Taper roller bearing

+ Higher axial and radial loads possible

### Simple bearing

+ For separate output shaft bearing only one bearing may be necessary

## Lubrication

### Synthetic fluid grease

+ No relubrication necessary

### Food-grade grease

+ Particularly usable in the food industry

### Low temperature-grade grease

+ For very low outdoor and operating temperatures

### Oil

+ Increased degree of efficiency

## Gear material

### Case-hardened and tempered steel

+ Precision ground surface material possible

### Non-ferrous metals

### Plastic

+ Optimized operational noise during lower torques  
+ Using injection molding, low unit costs possible with high quantities

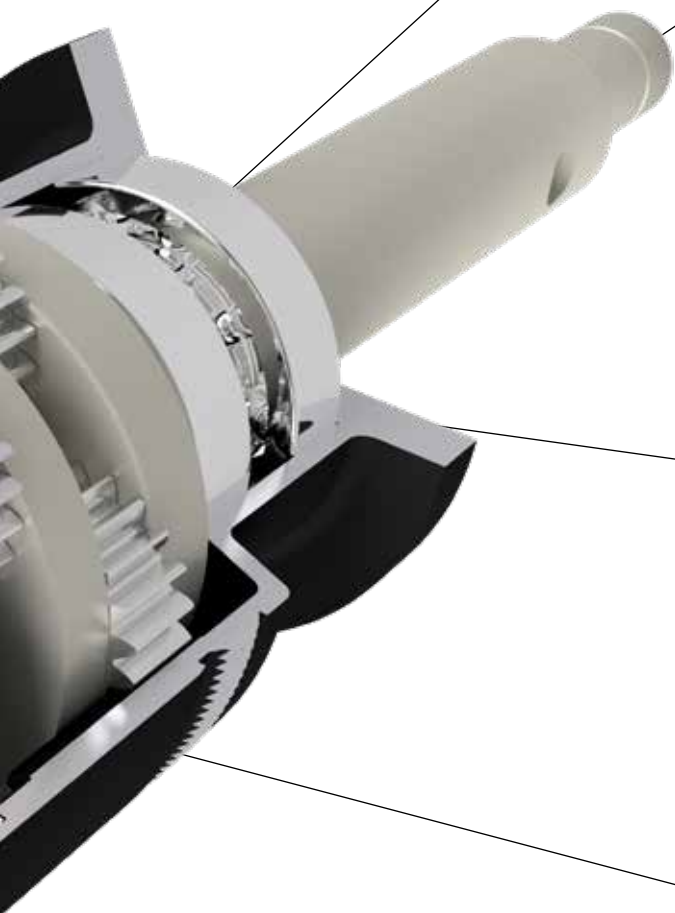

# Custom engineered planetary gears in use.

The driving force in many sectors.



## Underwater unwinding systems for swimming pools

Unwinding systems for pool covers are installed underwater and must therefore be absolutely watertight for years to come. For this demanding application, Framo Morat developed a special tubular motor that is doubly sealed using AQUASEAL technology and thus offers long-term corrosion resistance and is maintenance-free. The integrated 3-stage planetary gears consist of differing materials and supply a transmission of 1000:1 with an output torque of 300 Nm.



## Application examples



### Curved stair lifts

A substantial component of a curved stairlift's main drive is the planetary gear. It is built to be much more compact than other gearbox variants due to its coaxial design. Another advantage is that the aesthetics and the noise behavior of the system are improved. In fast-rotating gearbox stages, gear parts made from technical thermoplastics are used for noise reduction, while steel components are used in slowly rotating but powerfully loaded stages.



### Conveyor systems

Planetary gears are an indispensable element in drum motors for conveyor belts and rollers. The selection of 2-stage planetary gears made of plastic was mainly influenced by the need to keep noise generation as low as possible. The conveyors are driven forward by means of the friction between the drum motor and the belt.

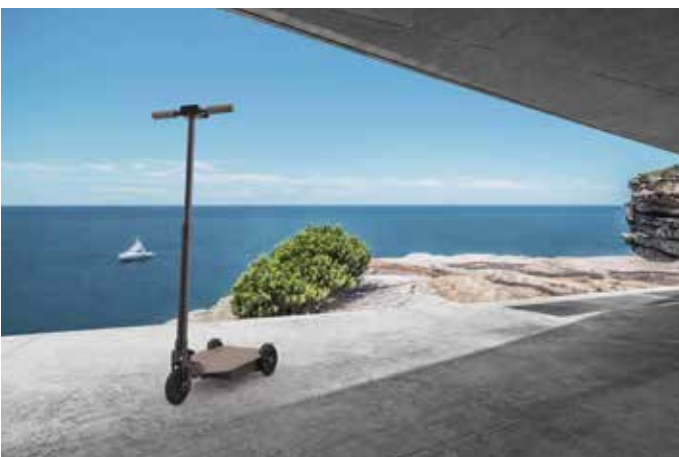

### Planetary gear for E-Scooter

Light, compact and powerful – these are the characteristics of the new E-scooter by SAEM. The specially developed steering mechanism and the innovative folding mechanism ensure driving fun and highest comfort. With a total weight of 6 kg, this E-scooter has a range of 15 km. The high-performance planetary gear from Framo Morat makes the scooter fit for every slope in town. This planetary gear convinces with its compact design, its light aluminum housing and its high gear ratio.



## Application examples



### Automated guided vehicles (AGV)

Customer-specific planetary gears are frequently used in automated guided vehicles (AGV) - whether in intra-logistics, medical device technology or agricultural technology. The gearboxes are used in wheel hub drives, as they enable a compact design in narrow spaces. The three-stage planetary gears with optimized bearings reach a high output torque of up to 300 Nm and a radial load of up to 12 kN.



### Mobile satellite receivers

Positioning accuracy is a basic requirement for mobile satellites, especially for receiver systems. This two-stage planetary gear from Framo Morat uses the gear's internal tension to reduce the circumferential backlash of the entire system. High quality signals can be received through manual control adjustments in the form of micromovements.



### High ratio gearbox systems for valve adjustments

Transmissions that have high gear ratios often take up a lot of space—especially with coaxial variants. In order to reduce installation space while at the same time operating at the required gear ratios, Framo Morat combines a worm gear stage and a planetary stage in a single gearbox. Thanks to the modular system and the high power density of the planetary gearbox series, as well as decades of experience in the manufacture of standard worm gear sets, Framo Morat offers a fast and low-cost solution. For medium to large quantities, complete custom designs and developments are also employed.





#### Tracking drive for mirror reflectors

This custom engineered drive is used to enable the tracking of mirror reflectors. During its development, great attention was paid to achieving minimum backlash and maximum torque. The drive achieves a maximum output torque of 5.000 Nm and consists of a servomotor, a 3-stage planetary gear, a worm gear, a position tracking system and two adapter plates.

A single drive moves a total mirror area of 330 m<sup>2</sup>. One special aspect of this development was the adapted size of the various planetary gear stages. The planetary gears achieve a transmission of 729:1.

## Step-by-step configuration of your planetary gear.

1. Transmission ratio		Unit	Formula
			$i = \frac{n_{1(A)}}{n_{2(A)}}$
2. Speed		Unit	Formula
	Output speed	rpm	$n_{2(A)} = \frac{n_{1(A)}}{i}$
		rpm	$n_{1(A)} = n_{2(A)} \cdot i$
	Input speed	rpm	$n_1 \leq n_{1(A)}$
		rpm	$n_{1max} \leq n_{1(A)max}$
3. Torque		Unit	Formula
	Nominal output torque	Nm	$T_{2N} \leq T_{2N(A)} \cdot h$
	Max. acceleration torque	Nm	$T_{2B} \leq T_{2B(A)} \cdot K_a \cdot b_B \cdot S$
	Emergency stop torque	Nm	$T_{2NOT} \leq T_{2max(A)} \cdot h$
4. Operation mode / Duty cycle		Unit	Formula
	Operation mode		$S1 \text{ or } S5$
		min	$ED(t) = t_a + t_c + t_{d(min)}$
	Duty cycle		
		%	$ED(\%) = \frac{ED(t)}{ED(t) + t_e} \cdot 100(\%)$
5. Backlash		Unit	Formula
		arcmin	$j_t \leq j_{t(A)}$
6. Noise		Unit	Formula
		dB (A)	$Q_g \leq Q_{g(A)}$
7. Motor		Unit	Formula
		Nm	$T_{2B} \leq T_{mB} \cdot i \cdot h \cdot K_S$

Legend	Explanation
$i$ = transmission ratio	

Legend	Explanation
$n_2$ = Output speed	
$n_1$ = Input speed	
$n_{1\max}$ = max. Input speed	

Legend	Explanation																			
$T_{2N}$ = Nominal output torque	Load factor $K_A$ (Standard = 1.0) <table border="1" style="margin-left: 20px;"> <thead> <tr> <th rowspan="2">Drive</th> <th colspan="3">Load type of the driven machine</th> </tr> <tr> <th>steady</th> <th>medium shocks</th> <th>heavy shocks</th> </tr> </thead> <tbody> <tr> <td>steady</td> <td>1.0</td> <td>1.25</td> <td>1.75</td> </tr> <tr> <td>medium shocks</td> <td>1.25</td> <td>1.5</td> <td>2.0</td> </tr> <tr> <td>heavy shocks</td> <td>1.5</td> <td>1.75</td> <td>2.25</td> </tr> </tbody> </table>	Drive	Load type of the driven machine			steady	medium shocks	heavy shocks	steady	1.0	1.25	1.75	medium shocks	1.25	1.5	2.0	heavy shocks	1.5	1.75	2.25
Drive	Load type of the driven machine																			
	steady	medium shocks	heavy shocks																	
steady	1.0	1.25	1.75																	
medium shocks	1.25	1.5	2.0																	
heavy shocks	1.5	1.75	2.25																	
$T_{2B}$ = Max. acceleration torque	Operational ratio $b_B$ (Standard = 1.0) <table border="1" style="margin-left: 20px;"> <thead> <tr> <th>Operational time</th> <th>4-8 h</th> <th>8-12 h</th> <th>&gt;= 12h</th> </tr> </thead> <tbody> <tr> <td>Operational time factor</td> <td>1.00</td> <td>1.20</td> <td>1.35</td> </tr> </tbody> </table>	Operational time	4-8 h	8-12 h	>= 12h	Operational time factor	1.00	1.20	1.35											
Operational time	4-8 h	8-12 h	>= 12h																	
Operational time factor	1.00	1.20	1.35																	
$T_{2NOT}$ = Emergency stop torque	S (Standard = 1.0) $\eta$ = see power tables																			

Legend	Explanation
$S_1$ : Continuous operation: ED > 60% and ED > 20 min $S_5$ : Cyclic operation: ED <= 60% and ED <= 20 min	
$t_b, t_c, t_d, t_e$ = Cycle times see table page 39	
ED (t) = Duty cycle in min	
ED (%) = Duty cycle in %	

Legend	Explanation
$j_i$ = Backlash $j_{i(A)}$ = Backlash of your application	1 arcmin $\cong$ 0.016°

Legend	Explanation
$Q_g$ = Noise level $Q_{g(A)}$ = Noise level of your application	

Legend	Explanation												
$T_{mB}$ = Motor-acceleration torque  Compare motor shaft diameter with input hollow shaft diameter	Service factor $K_S$ (Standard = 1.0) <table border="1" style="margin-left: 20px;"> <thead> <tr> <th><math>K_S</math></th> <th>No. of cycles / h</th> </tr> </thead> <tbody> <tr> <td>1.0</td> <td>0 - 1000</td> </tr> <tr> <td>1.1</td> <td>1000 - 1500</td> </tr> <tr> <td>1.3</td> <td>1500 - 2000</td> </tr> <tr> <td>1.6</td> <td>2000 - 3000</td> </tr> <tr> <td>1.8</td> <td>3000 - 5000</td> </tr> </tbody> </table>	$K_S$	No. of cycles / h	1.0	0 - 1000	1.1	1000 - 1500	1.3	1500 - 2000	1.6	2000 - 3000	1.8	3000 - 5000
$K_S$	No. of cycles / h												
1.0	0 - 1000												
1.1	1000 - 1500												
1.3	1500 - 2000												
1.6	2000 - 3000												
1.8	3000 - 5000												

8. Loads	Unit	Formula
Max. radial force	N	$F_{2r} \# F_{2rm(A)} = \sqrt[3]{\frac{n_{2a} \cdot t_a \cdot F_{2ra}^3 + n_{2c} \cdot t_c \cdot F_{2rc}^3 + n_{2d} \cdot t_d \cdot F_{2rd}^3}{n_{2a} \cdot t_a + n_{2c} \cdot t_c + n_{2d} \cdot t_d}}$
Max. axial force	N	$F_{2a} \# F_{2am(A)} = \sqrt[3]{\frac{n_{2a} \cdot t_a \cdot F_{2aa}^3 + n_{2c} \cdot t_c \cdot F_{2ac}^3 + n_{2d} \cdot t_d \cdot F_{2ad}^3}{n_{2a} \cdot t_a + n_{2c} \cdot t_c + n_{2d} \cdot t_d}}$
9. Life time	Unit	Formula
	h	<p>The service life of the gears depends on many different factors. Specifically, the service life can be defined through two different methods of calculation: Tooth system service life and bearing service life. Speed, gear ratio and torque are especially important influencing factors.</p> <p>The lower the output speed, the higher the service life.</p> <p>The lower the torque, the higher the service life.</p>

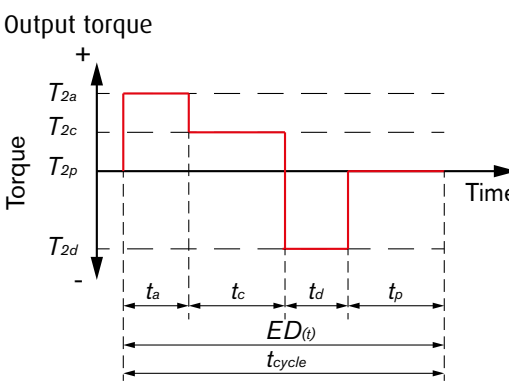
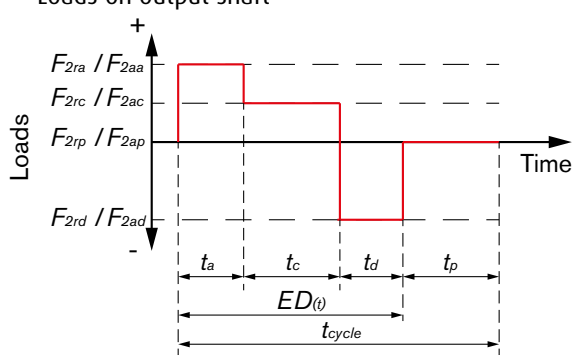
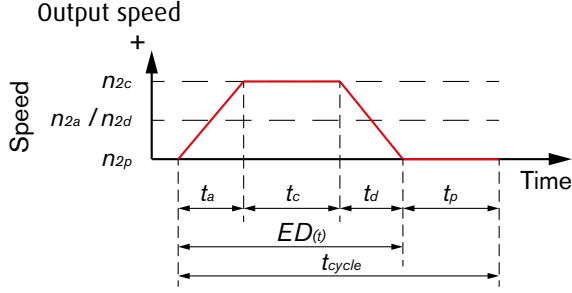
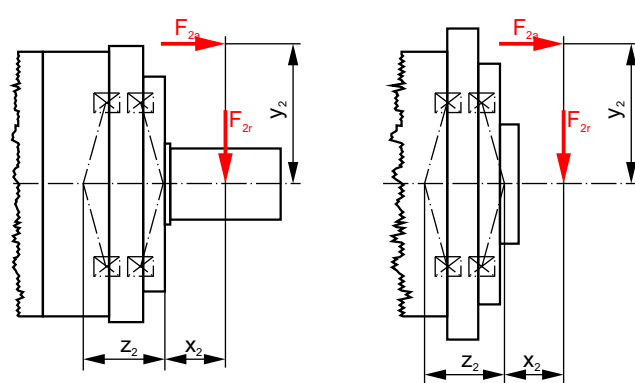
Legend	Explanation
<p> <math>F_r</math> = Radial force  <math>F_{2rm}</math> = Average radial force  <math>F_{2am(A)}</math> = Max. radial force  <math>F_{2ra}</math> = Acceleration radial force  <math>F_{2rc}</math> = Holding radial force  <math>F_{2rd}</math> = Deceleration radial force  <math>t_a</math> = Acceleration time  <math>t_c</math> = Holding time  <math>t_d</math> = Deceleration time  <math>n_{2a}</math> = Average acceleration output speed  <math>n_{2c}</math> = Holding output speed  <math>n_{2d}</math> = Average deceleration output speed  <math>n_{2p}</math> = Pause = 0  <math>t_p</math> = Pause  <math>F_{2rp}</math> = Pause = 0  <math>F_{2ap}</math> = Pause = 0  <math>t_{cycle}</math> = Cycle time                 </p>	<p><b>Output torque</b></p>  <p><b>Loads on output shaft</b></p> 
<p> <math>F_a</math> = Axial force  <math>F_{2am}</math> = Average axial force  <math>F_{2am(A)}</math> = Max. axial force  <math>F_{2aa}</math> = Acceleration axial force  <math>F_{2ac}</math> = Holding axial force  <math>F_{2ad}</math> = Deceleration axial force  <math>t_a</math> = Acceleration time  <math>t_c</math> = Holding time  <math>t_d</math> = Deceleration time  <math>n_{2a}</math> = Average acceleration output speed  <math>n_{2c}</math> = Holding output speed  <math>n_{2d}</math> = Average deceleration output speed  <math>n_{2p}</math> = Pause = 0  <math>t_p</math> = Pause  <math>F_{2rp}</math> = Pause = 0  <math>F_{2ap}</math> = Pause = 0  <math>t_{cycle}</math> = Cycle time                 </p>	<p><b>Output speed</b></p>  <p><b>Force diagrams</b></p> 
Legend	Explanation



### Definition of serial number

	Internal Group No.	-	Type	Size	-	Center diam.	-	Counting
G-series	3	-	G	090	-	090	-	001
G-series	3	-	G	120	-	110	-	003

## Motorflanges

Gearboxes	Flange SQ	Flange thread G	Article - No.	Center diameter Z	Bore hole diam. LK	Max. center depth LZ	Max motor shaft length L	Mounting bore B
GSA050	46 x 46	M4	3-G044-030-001	30	46	4	25	4,5
GSB044	55 x 55	M4	3-G044-040-002	40	63	4	25	4,5
GSB062 2st.	60 x 60	M5	3-G044-050-002	50	70	3	25	5,5
GSF062 2st.	60 x 60	M4	3-G044-050-004	50	70	3	30	4,5
GSD047	60 x 60	M4	3-G044-050-004	50	70	3	30	4,5
GSD064 2st.GSBL044	70 x 70	M5	3-G044-060-001	60	75	4	25	5,5
GSBL062 2st.								
GSN050	70 x 70	M5	3-G044-060-001	60	75	4	25	5,5
GSN060								
GFE050	70 x 70	M5	3-G044-060-001	60	75	4	25	5,5
GSA070								
GSB062 1st.	64 x 64	M4	3-G062-030-001	30	46	5	30	4,5
GSB090 2st.	64 x 64	M5	3-G062-050-001	50	70	5	30	5,5
GSF062 1st.	64 x 64	M4	3-G062-050-002	50	70	5	30	4,5
GSF075 2st.	82 x 82	M6	3-G062-050-004	50	95	5	30	6,6
GSD064 1st.	70 x 70	M6	3-G062-060-001	60	75	5	30	6,6
GSD090 2st.	70 x 70	M5	3-G062-060-002	60	75	5	30	5,5
GSBL062 1st.	80 x 80	M6	3-G062-070-102	70	90	5	40	6,6
GSBL090 2st.	80 x 80	M5	3-G062-070-003	70	90	5	30	5,5
GSN070	80 x 80	M5	3-G062-070-003	70	90	5	30	5,5
GFE070	90 x 90	M6	3-G062-080-001	80	100	5	30	6,6
GSA090	92 x 92	M6	3-G090-070-001	70	90	8	50	6,6
GSB090 1st.	92 x 92	M5	3-G090-070-002	70	90	8	50	5,5
GSB120 2st.	92 x 92	M6	3-G090-080-001	80	100	8	50	6,6
GSF075 1st.	110 x 110	M8	3-G090-095-002	95	115	8	50	9
GSF100 2st.	110 x 110	M8	3-G090-095-003	95	130	8	50	9
GSD090 1st.	110 x 110	M8	3-G090-095-006	95	115	13	55	9
GSD110 2st.	110 x 110	M8	3-G090-095-006	95	115	13	55	9
GSBL090 1st.	130 x 130	M8	3-G090-110-001	110	145	8	50	9
GSBL120 2st.	130 x 130	M8	3-G090-110-002	110	145	22	65	9
GSN080	130 x 130	M8	3-G090-110-003	110	130	8	50	9
GSN090	130 x 130	M8	3-G090-110-003	110	130	8	50	9
GSN115	142 x 142	M10	3-G090-130-001	130	165	8	50	11
GFE090	142 x 142	M10	3-G090-130-001	130	165	8	50	11
GSA120	122 x 122	M6	3-G120-070-001	70	90	9	63	6,6
GSA160	122 x 122	M8	3-G120-095-002	95	115	9	63	9
GSB120 1st.	130 x 130	M8	3-G120-110-001	110	145	9	63	9
GSB142 2st.	130 x 130	M8	3-G120-110-003	110	130	9	63	9
GSF100 1st.	130 x 130	M8	3-G120-110-003	110	130	9	63	9
GSF142 2st.	150 x 150	M10	3-G120-110-005	110	165	9	63	11
GSD110 1st.	150 x 150	M10	3-G120-130-001	130	165	9	63	11
GSD140 2st.								
GSBL120 1st.	150 x 150	M10	3-G120-130-001	130	165	9	63	11
GSBL142 2st.								
GSN160	150 x 150	M10	3-G120-130-001	130	165	9	63	11
GFE120								

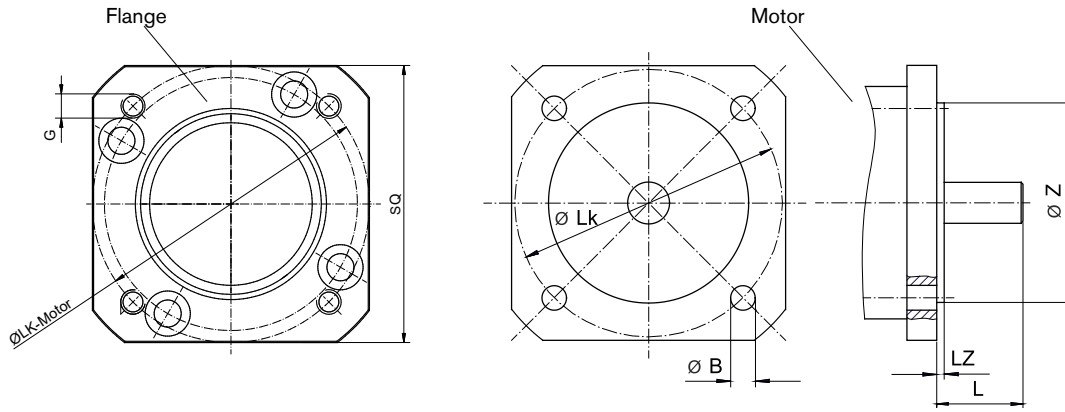

Gearboxes	Flange SQ	Flange thread G	Article - No.	Center diameter Z	Bore hole diam. LK	Max. center depth LZ	Max motor shaft length L	Mounting bore B
GSB142 1st. GSB180 2st. GSF142 1st.	180 x 180	M12	3-G142-114-001	114,3	200	8	80	13,5
GSF180 2st. GSD140 1st. GSBL142 1st. GSBL180 2st. GFE145	220 x 220	M12	3-G142-200-001	200	235	8	80	13,5
GSB180 1st. GSF180 1st. GSBL180 1st. GFE180 GFE220	182 x 182	M12	3-G180-114-001	114,3	200	13	115	13,5
	220 x 220	M12	3-G180-200-001	200	235	13	115	13,5
	222 x 222	M12	3-G220-200-001	114,3	200	13	115	13,5

\* This table shows a selection of the most common motor flanges. Contact us if you do not find the flange you are looking for!





# Your idea – Our drive.

For us, everything revolves around you.



With 100+ years of experience in the areas of gearwheel technology, worm gear sets and drive systems, Framo Morat supplies a comprehensive range of products that cover a wide spectrum of applications. In addition to our complete range of standard products, we also design and implement custom engineered drive solutions.

Framo Morat is your reliable partner for worm, spur or planetary gears; complete gearmotors; and complex drive systems – and for your drive concept too!

## Gear technology

---

Gearwheels with internal or external tooth systems, rotor shafts, pinions and chain pulleys according to individual customer requirements.

## Worm gear sets

---

Framo Morat is a leading international supplier – manufacturing over 1 million gear sets a year, a major proportion of which are produced to customer specifications.

## Plastic injection molding technology

---

In the field of precision injection molding technology, we produce gear parts, plastic/metal connections or technical parts for individual tasks.

## Drive technology

---

Our innovative standard drives such as planetary gears, linear or rotary actuators, as well as complete custom engineered drive solutions, are in use in numerous applications.

### Germany

**Franz Morat Holding GmbH & Co. KG**  
Franz-Morat-Straße 6  
79871 Eisenbach  
Phone +49 (0) 7657 88-0  
E-Mail [info@franz-morat.com](mailto:info@franz-morat.com)  
[de.franz-morat.com](http://de.franz-morat.com)

### USA

**Framo Morat, Inc.**  
Offices in:  
**GA / IL / TX / NM**  
Phone 505 359-2949  
E-Mail [usa@framo-morat.com](mailto:usa@framo-morat.com)  
[us.framo-morat.com](http://us.framo-morat.com)

### Turkey

**Framo Morat Hareketli Sistemler San. ve Tic. Ltd. Şti.**  
Çobançeşme Mah. Sanayi Cad. No:44/C  
Nış İstanbul Residence K:6/70 B.Evler/  
İSTANBUL  
E-Mail [cem@framo-morat.com](mailto:cem@framo-morat.com)  
[tr.framo-morat.com](http://tr.framo-morat.com)