

Neco[®] - Precision gears

Compact, robust, precise

NEW

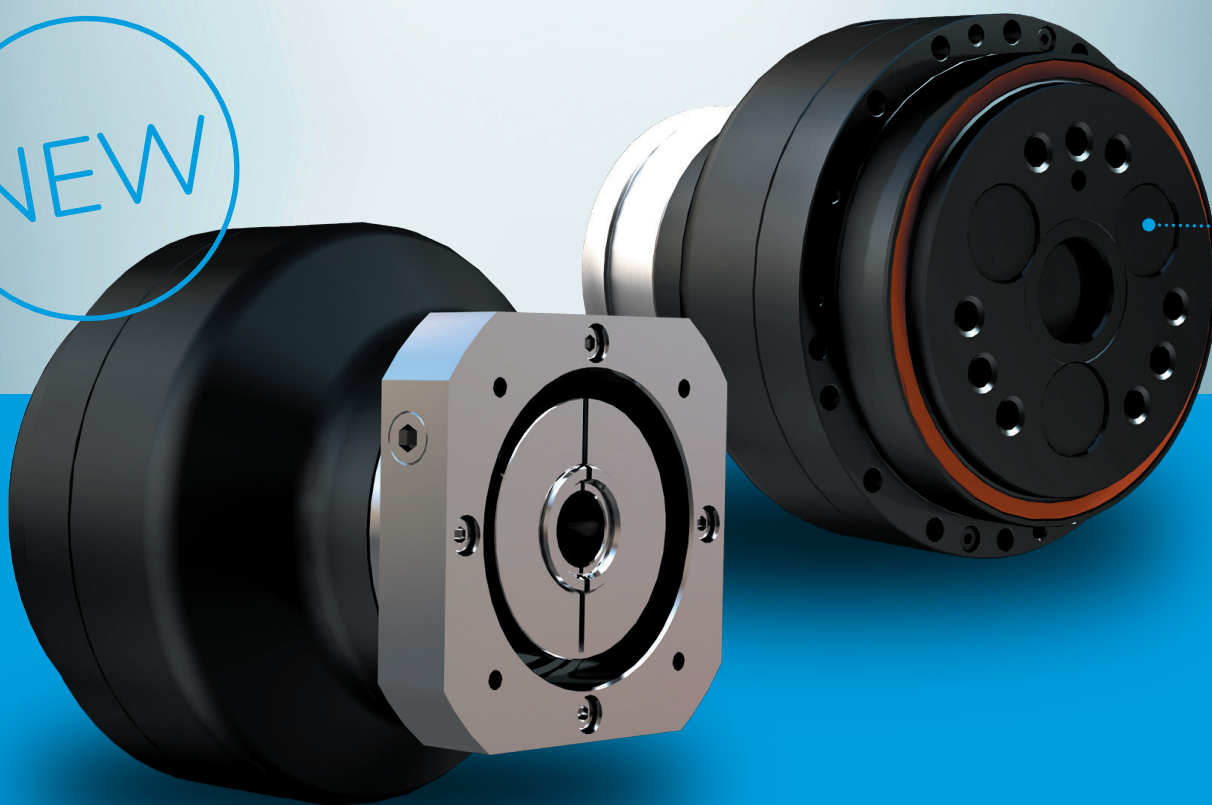

Nabtesco

Welcome to the new **N**eco[®] world

The advantages

- Extreme precision (hysteresis loss < 0.5 arc.min)
- High shock load (500 % the rated torque)
- Economical plug-and-play solution
- Modular system
- Comprehensive corrosion protection
- Clean, enclosed design
- Maximum flexibility in the motor connection
- Low-inertia clamping ring for more dynamic cycles
- Minimum engineering and installation required
- Designed for a long life and low maintenance

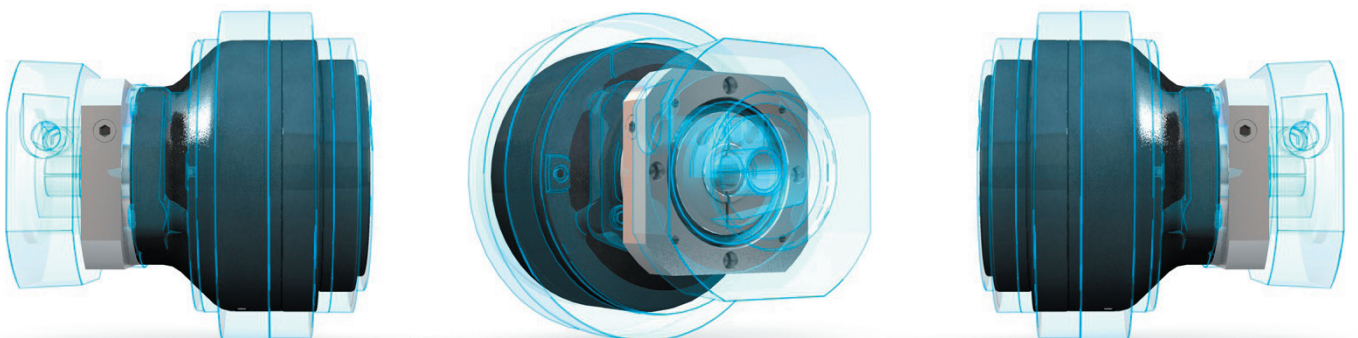
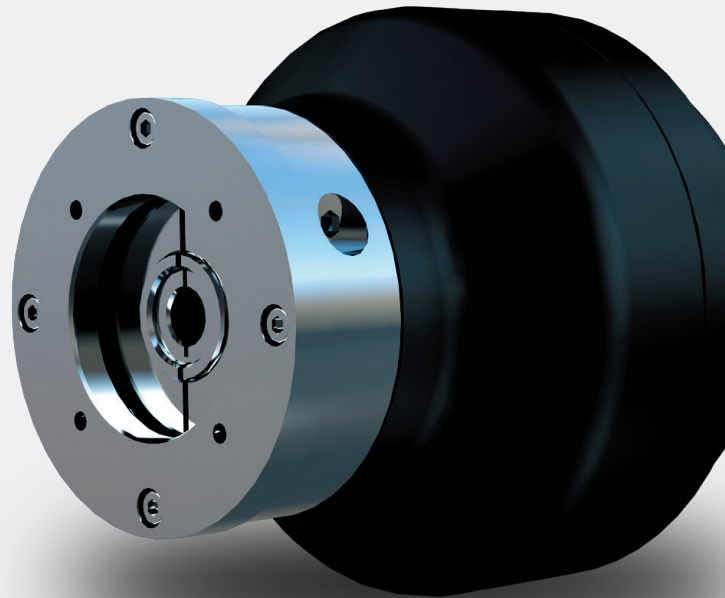

The servo gearboxes of the new **Neco**[®] series are based on the gear units of the RH-N series. They feature high power density, extremely effective corrosion protection, and maximum flexibility in the motor connection – all in an elegant and compact design. Furthermore, we have developed a modular system that allows the customer to configure a custom gearbox quickly and easily.

The **Neco**[®] servo gearboxes achieve high precision with a hysteresis loss of only 0.5 arc.min and are extremely robust, due to dual-bearing eccentric shafts and a bearing-mounted input shaft. The motor shaft is adapted by means of a radial clamping ring with a low-inertia design. The ring reduces inertia on the motor shaft by up to 39 % to enable extremely dynamic cycles.

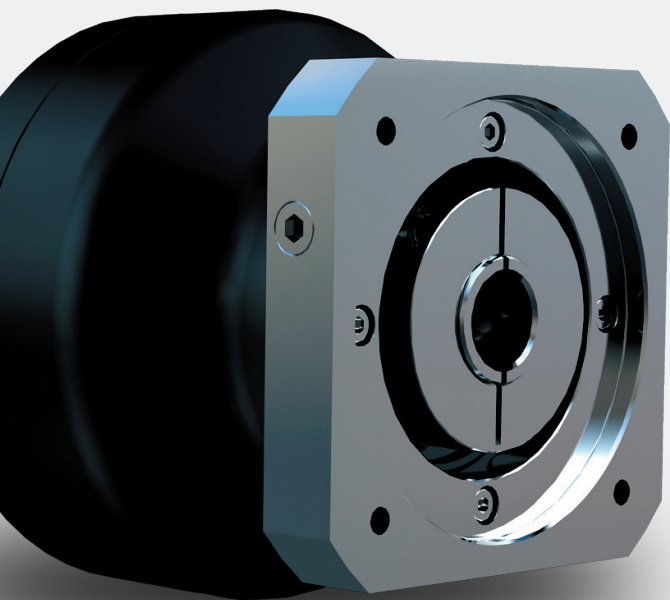

Experience gears in a new way – it's so easy

Easy to find:

New quickfinder helps you find the right cycloidal gearbox faster

Easy to size:

Configure your custom gearbox fast and easy right on the website in only 3 steps (see following pages)

Easy to handle:

The QR code on the gears gives you direct access to manual videos, operating manuals and live support



Innovative, efficient gear concept



Ready to install and user-friendly



Blackbox concept minimises risks

Cycloidal gears – Mode of operation

Cycloidal gears offer unbeatable advantages

The two-stage reduction of cycloidal gears makes solutions from Nabtesco so successful. The reason is that the speed is reduced by the double cams. In addition, vibration is reduced by the two-stage reduction principle and low inertia. The force is also distributed very evenly, thanks to the roller cam design, and this contributes to the minimum hysteresis loss and enormous resistance to shock loading. Consequently, cycloidal gears are as versatile as they are resilient.

The drive or servomotor is connected to the spur gear stage of the gearbox via a pinion. The rotating speed reduces at this point relative to the reduction ratio between the pinion and planetary gear. The planetary gears are connected to crankshafts which drive the cams using needle bearings. These cams rotate inside the case which is lined with pins.

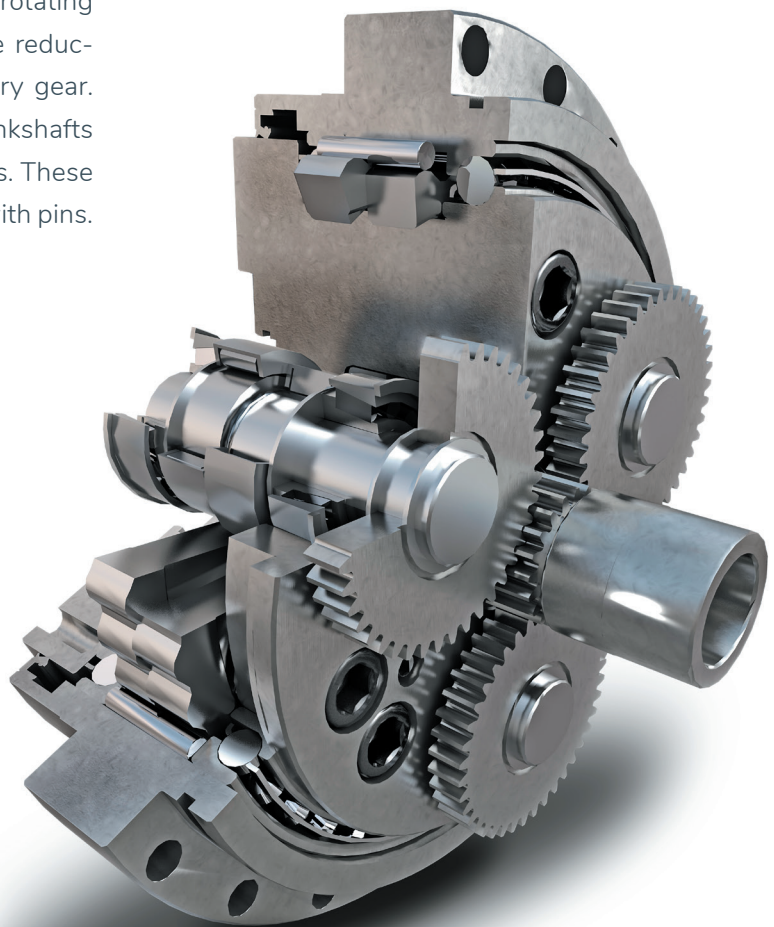

The advantages

- High rated torque of up to 28,000 Nm
- Minimum space required
- High shock load (5 times the rated torque)
- Extreme precision (hysteresis loss < 1 arcmin)
- High rigidity
- Low inertia
- Insensitive to vibrations
- Extremely low wear
- Long service life



**extremely precise and high
positioning accuracy**



**extremely robust, durable
and low-wear**



**extremely compact and
lightweight design**

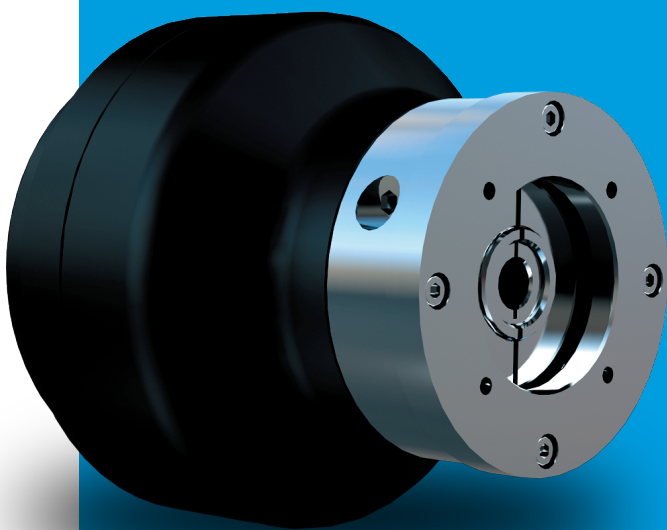

The RV principle: Reliable and precise cycloidal gearboxes

Visit also our channel on Youtube. Simply scan the QR code and discover the explanatory video on Nabtesco's two-stage reduction principle.



Neco® line up at a glance

Example material short text:

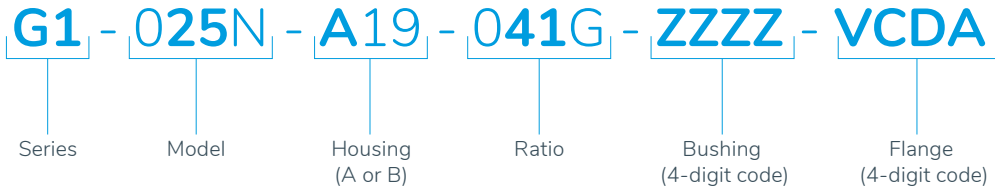

	Series	Model	Housing (A or B)*	Ratio	Bushing (4-digit code)	Flange (4-digit code)
Example:	G1	-025N	-A19	-041G**	-ZZZZ	-VCDA
Neco		25	A19	41 63 81	See page 8	See page 8
			B19	107,66 126 137 164,07		
		42	A24	41 61 81 93	See page 12	See page 12
			B24	105 126 141 164,07		
		80	A32	41 81 101 129	See page 16	See page 16
			B32	141 171		
		125	A35	41 81 102,17 121	See page 20	See page 20
			B35	145,61 161		
		160	A35	41 81 102,81 125,21	See page 24	See page 24
			B35	156 201		

* A type: screwed from the output side / B type: screwed from the drive side

** G: ground tothing

Configure your gearbox

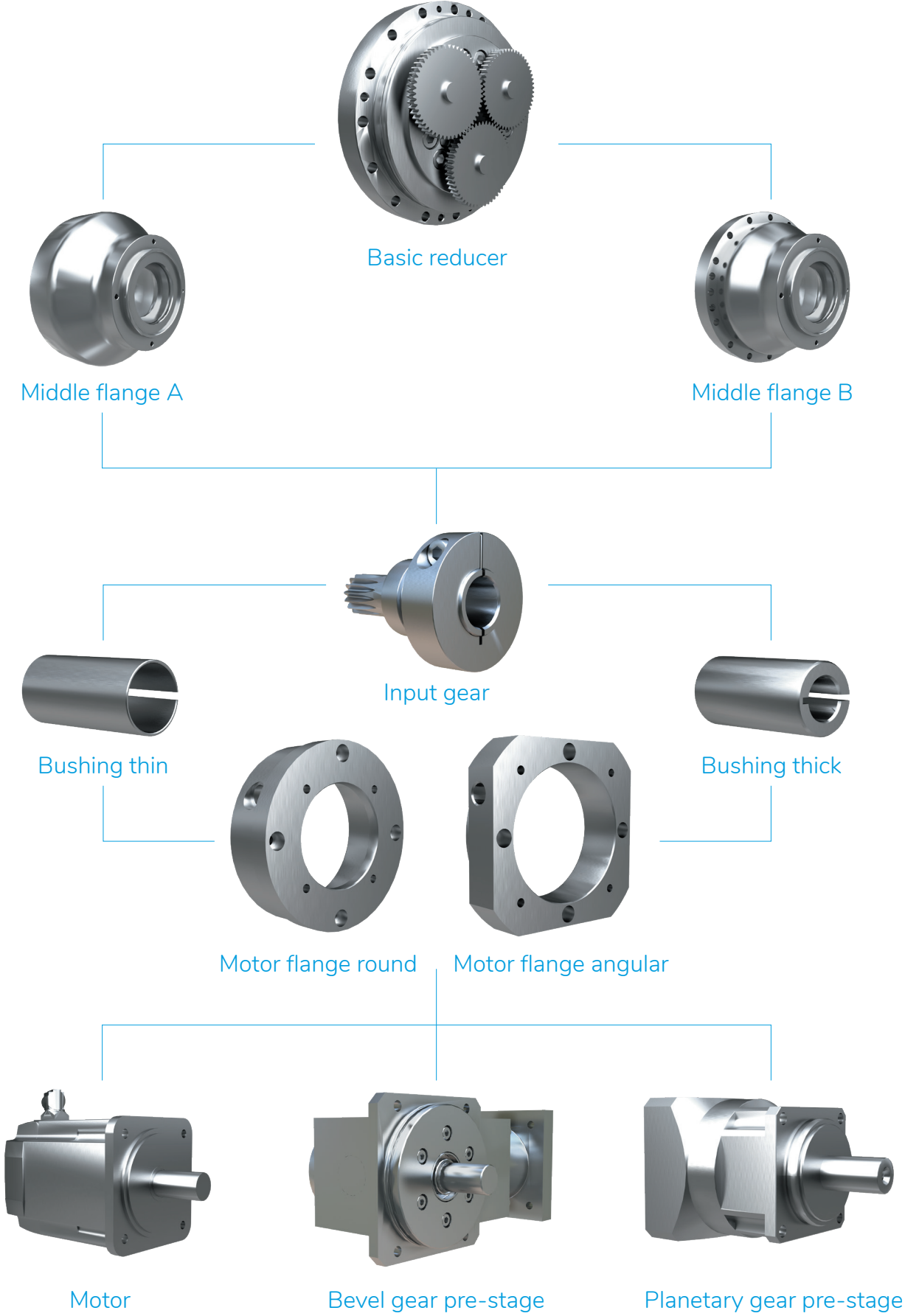

Series Neco[®]-25

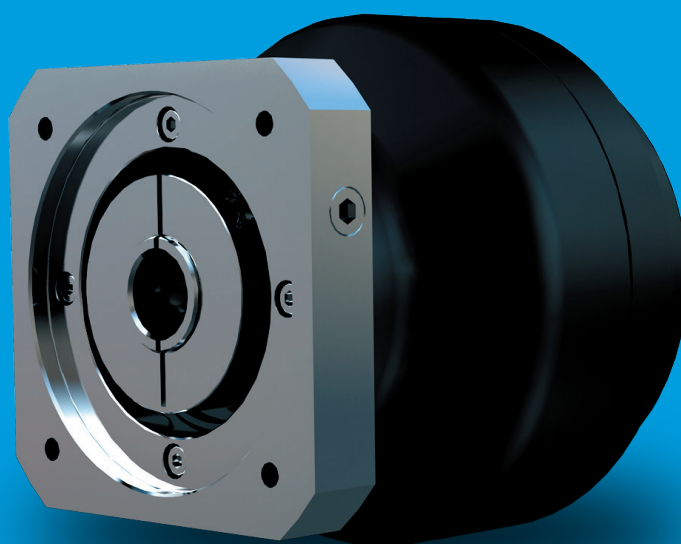

Series Neco®-25

Technical Data Sheet

Reference Product			*1	G1025Nx19						
Rated Output Torque	T_0	Nm	*2	245						
Rated Output Speed	N_0	rpm	*2	15						
Rated Service Life	K	hrs	*2	6,000						
Ratio	R		*3	41	63	81	107.66	126	137	164.07
Allow. Acc./Dec. Torque	T_{S1}	Nm		612						
Mom.max.allow. Torque (E-Stop)	T_{S2}	Nm		1,225						
Allowable Output Speed [100 %]	N_{S0}	rpm	*4	57						
Allowable Output Speed [40 %]	N_{S1}	rpm	*4	110						
Hysteresis Loss		arc.min		0.5						
Angular Transm. Error (max.)		arc.sec		70						
Allow. Tilting Moment	M_{01}	Nm	*5	784						
Mom. Allow. Tilting Moment	M_{02}	Nm		1,568						
Allowable Radial Load	W_r	N	*6	6,975						
Torsional Rigidity (Ref.)		Nm/ arc.min		61						
Startup Efficiency (Typical Value)		%		80						
Ambient Temperature		°C		-10 ... +40						
Allowable Reducer Case Temperatur		°C	*7	-10 ... +60						
Surface Protection			*8	Standard Nabtesco SS-A and black oxidized. Motor adaptation in aluminum. (undefined corrosion protection class)						
Lubricant			*9	Nabtesco RV-Grease						
Motor Interface				Motor Interface acc. Customer request						
Motor Adaption	md	mm	*10	Ø 14 ... 19 k6/j6/h6			straight shaft (w/o Key Way)			
Connection Type				Radial Clamping Ring						
Limit Allow. Input Torque			*11	Depending on the selected reduction and/or motor shaft, a limitation may be necessary						

Series Neco®-25

Easy to size

Configure your desired gearbox quickly and easily in just 3 steps:

1. Ratio

Ratio						
41	63	81	107.66	126	137	164.07

2. Bushing

Code	B1 [mm]	B2 [mm]	LB [mm]
ZZZZ	19	without bushing	
C16A		16	38
C14A		14	38

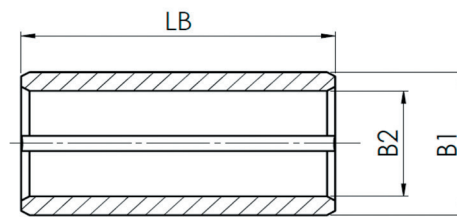

3. Motor adapter

Code	D1 [mm]	D2 [mm]	G1 [mm]	G2 [mm]	E [mm]	F [mm]	L1 [mm]	L2 [mm]	L3 [mm]	M [mm]	Gearbox Weight [kg]
ZZZZ	14 ... 19	without motor adapter									
VCDA		60F7	5	3.4	75	M6/12	141	17 ... 41	23	□80	6.6
VCDB		60F7	5	3.4	75	M5/10	141	17 ... 41	23	□80	6.6
VCEA		70F7	5	4.4	90	M5/10	142	18 ... 42	24	□84	6.6
VCFA		80F7	5	3.4	100	M6	140	17 ... 41	22	□98	6.7

Series Neco[®]-42

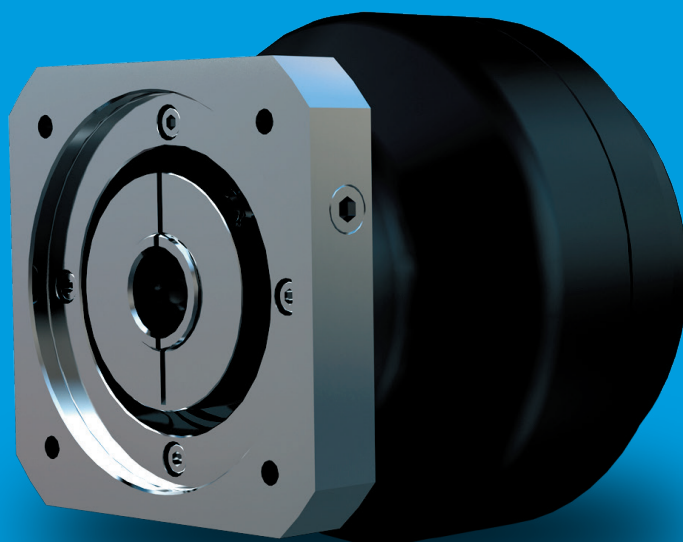

Series Neco®-42

Technical Data

Reference Product			*1	G1042Nx24 ...							
Rated Output Torque	T_0	Nm	*2	412							
Rated Output Speed	N_0	rpm	*2	15							
Rated Service Life	K	hrs	*2	6,000							
Ratio	R		*3	41	61	81	93	105	126	141	164.07
Allow. Acc./Dec. Torque	T_{S1}	Nm		1,029							
Mom.max.allow. Torque (E-Stop)	T_{S2}	Nm		2,058							
Allowable Output Speed [100 %]	N_{S0}	rpm	*4	52							
Allowable Output Speed [40 %]	N_{S1}	rpm	*4	100							
Hysteresis Loss		arc.min		0.5							
Angular Transm. Error (max.)		arc.sec		60							
Allow. Tilting Moment	M_{01}	Nm	*5	1,660							
Mom. Allow. Tilting Moment	M_{02}	Nm		3,320							
Allowable Radial Load	W_r	N	*6	12,662							
Torsional Rigidity (Ref.)		Nm/ arc.min		113							
Startup Efficiency (Typical Value)		%		80							
Ambient Temperature		°C		-10 ... +40							
Allowable Reducer Case Temperatur		°C	*7	-10 ... +60							
Surface Protection			*8	Standard Nabtesco SS-A and black oxidized. Motor adaptation in aluminum. (undefined corrosion protection class)							
Lubricant			*9	Nabtesco RV-Grease							
Motor Interface				Motor Interface acc. Customer request							
Motor Adaption	md	mm	*10	Ø 14 ... 24 k6/j6/h6				straight shaft (w/o Key Way)			
Connection Type				Radial Clamping Ring							
Limit Allow. Input Torque			*11	Depending on the selected reduction and/or motor shaft, a limitation may be necessary							

Series Neco®-42

Technical drawing 42-A

With motor adapter

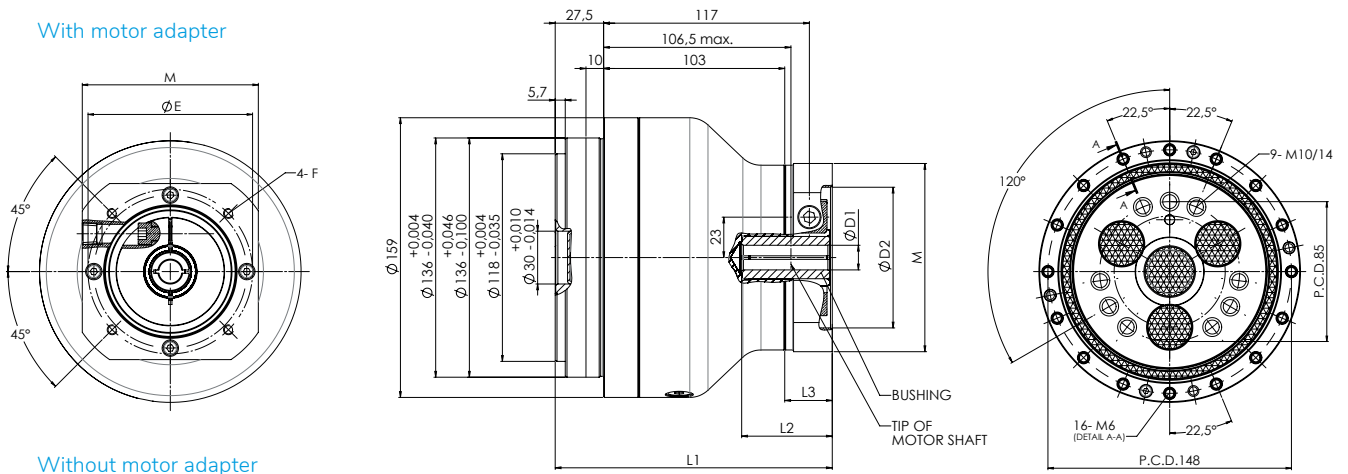

Without motor adapter

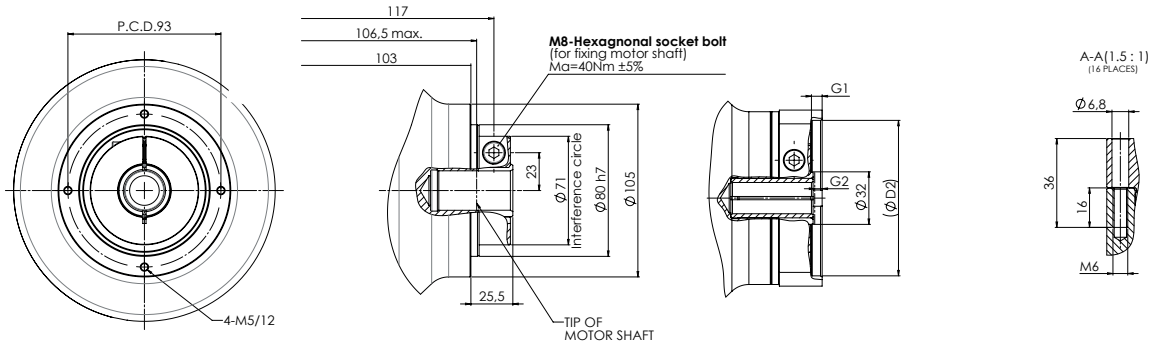

Technical drawing 42-B

With motor adapter

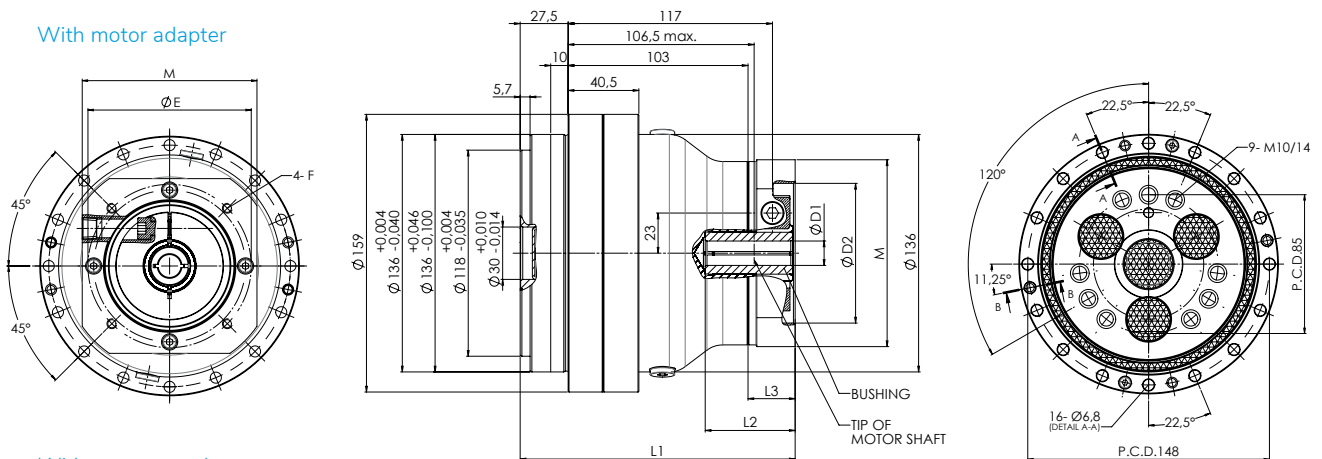

Without motor adapter

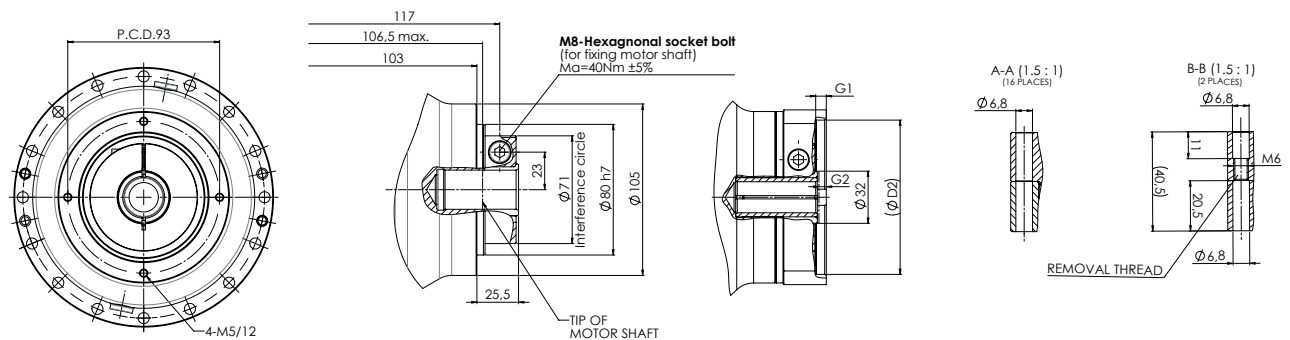

Series Neco®-42

Easy to size

Configure your desired gearbox quickly and easily in just 3 steps:

1. Ratio

Ratio							
41	61	81	93	105	126	141	164.07

2. Bushing

Code	B1 [mm]	B2 [mm]	LB [mm]
ZZZZ	24	without bushing	
D22A		22	50
D20A		20	
D19A		19	
D16A		16	
D14A		14	

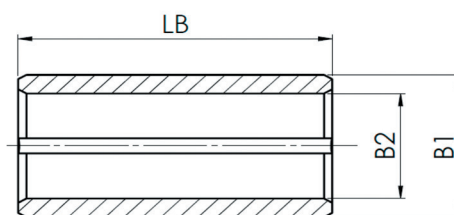

3. Motor adapter

Code	D1 [mm]	D2 [mm]	G1 [mm]	G2 [mm]	E [mm]	F [mm]	L1 [mm]	L2 [mm]	L3 [mm]	M [mm]	Gearbox Weight [kg]
ZZZZ	14 ... 24	without motor adapter									
VEDA		60F7	7.5	7.5	75	M6/12	165.5	30 ... 58	34	Ø 108	10.9
VEEA		70F7	8.5	8.5	90	M5/12	166.5	30 ... 58	34	Ø 112	10.9
VEFA		80F7	8	0.5	100	M6/12	158.5	24 ... 50	27	□ 107	10.9
VEGA		95F7	6.5	4.5	115	M8/15	162.5	27 ... 55	31	□ 107	10.9
VEHA		110F7	6.5	0.5	130	M8/15	158.5	24 ... 50	27	□ 128	11.1
VEHB		110F7	8	15.5	145	M8/16	173.5	38 ... 66	42	□ 132	11.2
VEKA		130F7	14	8.5	165	M10/20	166.5	32 ... 58	35	□ 157	11.8

Series Neco[®]-80

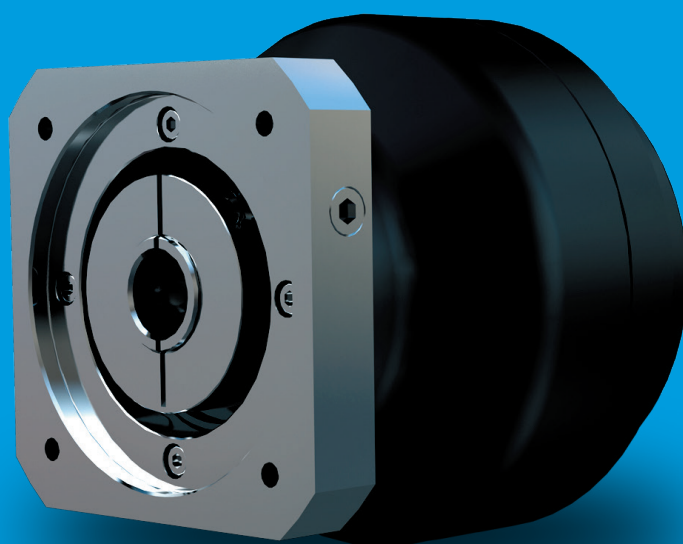

Series Neco®-80

Technical Data

Reference Product			*1	G1080Nx32...					
Rated Output Torque	T_0	Nm	*2	784					
Rated Output Speed	N_0	rpm	*2	15					
Rated Service Life	K	hrs	*2	6,000					
Ratio	R		*3	41	81	101	129	141	171
Allow. Acc./Dec. Torque	T_{S1}	Nm		1,960					
Mom.max.allow. Torque (E-Stop)	T_{S2}	Nm		3,920					
Allowable Output Speed [100 %]	N_{S0}	rpm	*4	40					
Allowable Output Speed [40 %]	N_{S1}	rpm	*4	88					
Hysteresis Loss		arc.min		0,5					
Angular Transm. Error (max.)		arc.sec		50					
Allow. Tilting Moment	M_{01}	Nm	*5	2,150					
Mom. Allow. Tilting Moment	M_{02}	Nm		4,300					
Allowable Radial Load	W_r	N	*6	14,163					
Torsional Rigidity (Ref.)		Nm/ arc.min		212					
Startup Efficiency (Typical Value)		%		80					
Ambient Temperature		°C		-10 ... +40					
Allowable Reducer Case Temperatur		°C	*7	-10 ... +60					
Surface Protection			*8	Standard Nabtesco SS-A and black oxidized. Motor adaptation in aluminum. (undefined corrosion protection class)					
Lubricant			*9	Nabtesco RV-Grease					
Motor Interface				Motor Interface acc. Customer request					
Motor Adaption	md	mm	*10	Ø 19 ... 32 k6/j6/h6		straight shaft (w/o Key Way)			
Connection Type				Radial Clamping Ring					
Limit Allow. Input Torque			*11	Depending on the selected reduction and/or motor shaft, a limitation may be necessary					

Series Neco®-80

Technical Data 80-A

With motor adapter

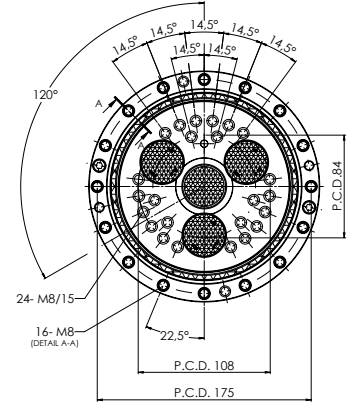
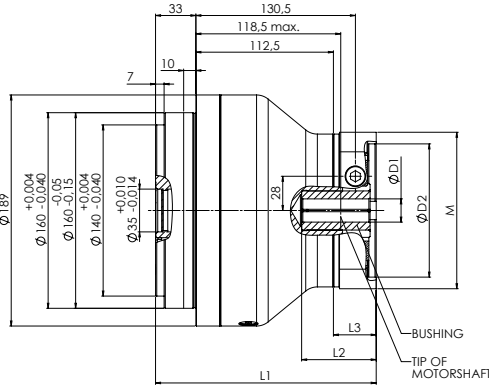
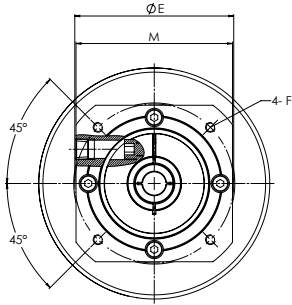

Without motor adapter

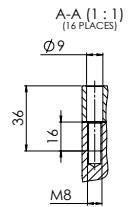
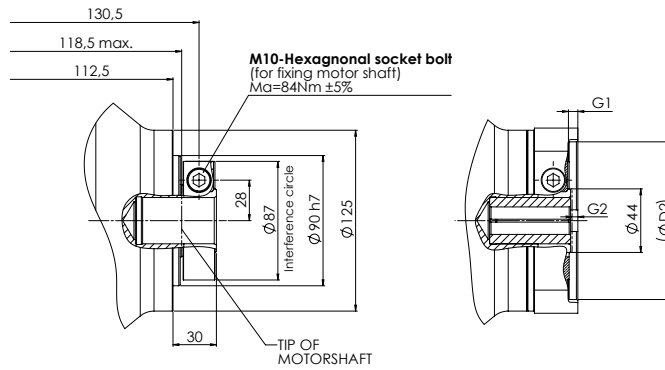
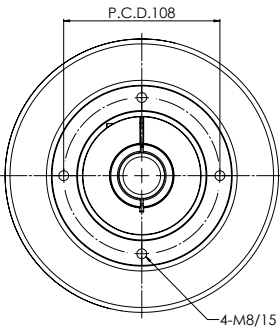

Technical Data 80-B

With motor adapter

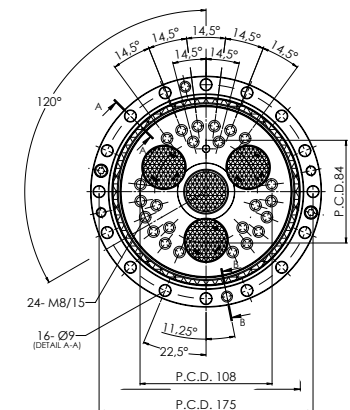
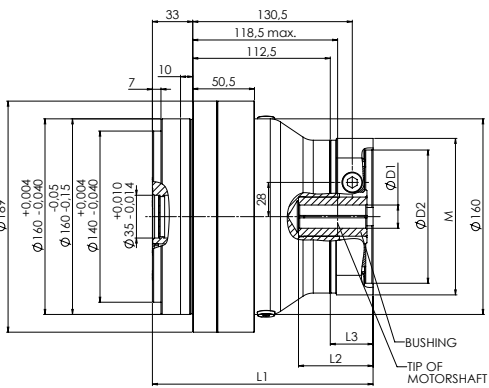
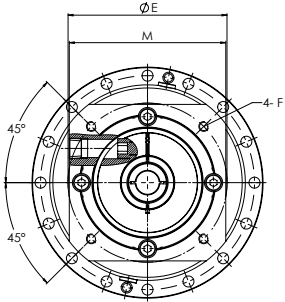

Without motor adapter

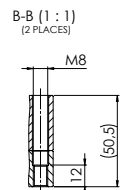
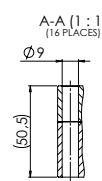
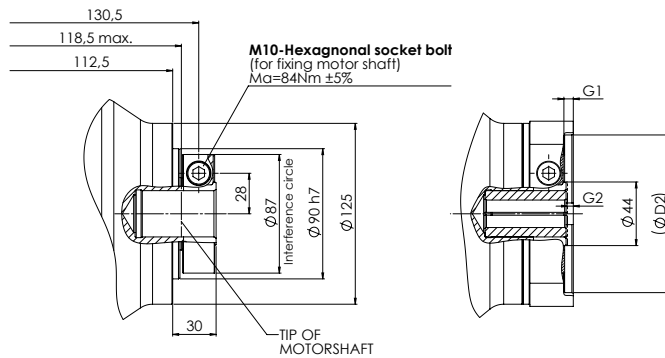
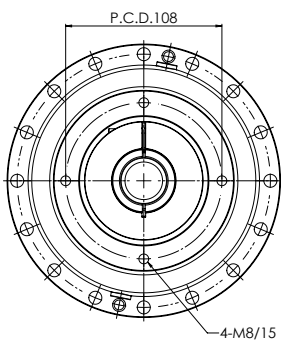

Series Neco®-80

Easy to size

Configure your desired gearbox quickly and easily in just 3 steps:

1. Ratio

Ratio					
41	81	101	129	141	171

2. Bushing

Code	B1 [mm]	B2 [mm]	LB [mm]
ZZZZ	32	without bushing	
E28A		28	56
E25A		25	
E24A		24	
E22A		22	
E20A		20	
E19A		19	

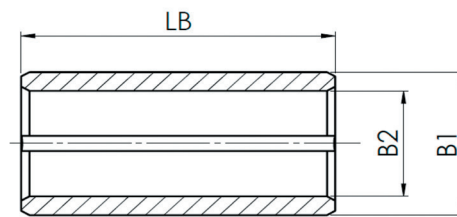

3. Motor adapter

Code	D1 [mm]	D2 [mm]	G1 [mm]	G2 [mm]	E [mm]	F [mm]	L1 [mm]	L2 [mm]	L3 [mm]	M [mm]	Gearbox Weight [kg]
ZZZZ	19 ... 32	without motor adapter									
VGFA		80F7	5	5	100	M6/12	182.5	30 ... 60	36	Ø 128	16.1
VGGA		95F7	11	25.5	145	M8/20	203	50 ... 80	56.5	□ 132	16.6
VGHA		110F7	6.5	4	130	M8/16	181.5	30 ... 60	35	□ 128	16.3
VGHB		110F7	8	15.5	145	M8/16	193	41 ... 71	46.5	□ 132	16.4
VGHC		110F7	6.5	9	130	M8/16	186.5	34 ... 66	40	□ 128	16.4
VGKA		130F7	5	4	165	M10/18	181.5	30 ... 60	35	□ 157	16.9

Series Neco[®]-125

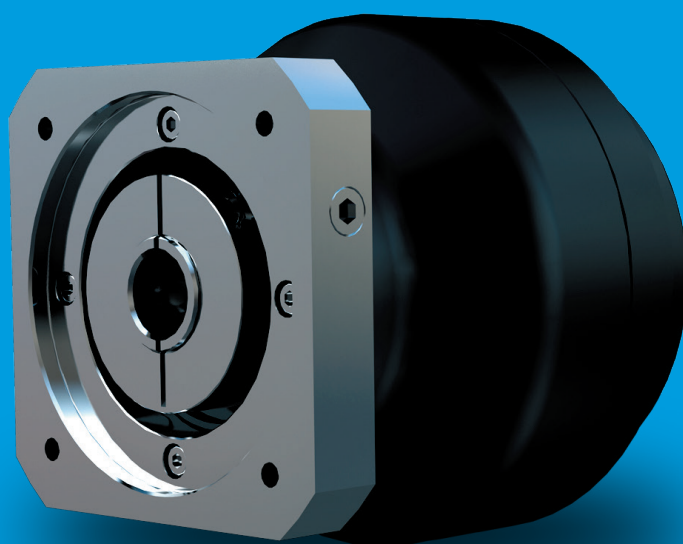

Series Neco®-125

Technical Data

Reference Product			*1	G1125Nx35 ...					
Rated Output Torque	T_0	Nm	*2	1,225					
Rated Output Speed	N_0	rpm	*2	15					
Rated Service Life	K	hrs	*2	6,000					
Ratio	R		*3	41	81	102.17	121	145.61	161
Allow. Acc./Dec. Torque	T_{S1}	Nm		3,062					
Mom.max.allow. Torque (E-Stop)	T_{S2}	Nm		6,125					
Allowable Output Speed [100 %]	N_{S0}	rpm	*4	35					
Allowable Output Speed [40 %]	N_{S1}	rpm	*4	79					
Hysteresis Loss		arc.min		0,5					
Angular Transm. Error (max.)		arc.sec		50					
Allow. Tilting Moment	M_{01}	Nm	*5	3,430					
Mom. Allow. Tilting Moment	M_{02}	Nm		6,860					
Allowable Radial Load	W_r	N	*6	19,804					
Torsional Rigidity (Ref.)		Nm/ arc.min		334					
Startup Efficiency (Typical Value)		%		80					
Ambient Temperature		°C		-10 ... +40					
Allowable Reducer Case Temperatur		°C	*7	-10 ... +60					
Surface Protection			*8	Standard Nabtesco SS-A and black oxidized. Motor adaptation in aluminum. (undefined corrosion protection class)					
Lubricant			*9	Nabtesco RV-Grease					
Motor Interface				Motor Interface acc. Customer request					
Motor Adaption	md	mm	*10	Ø 19 ... 35 k6/j6/h6			straight shaft (w/o Key Way)		
Connection Type				Radial Clamping Ring					
Limit Allow. Input Torque			*11	Depending on the selected reduction and/or motor shaft, a limitation may be necessary					

Series Neco®-125

Technical drawing 125-A

With motor adapter

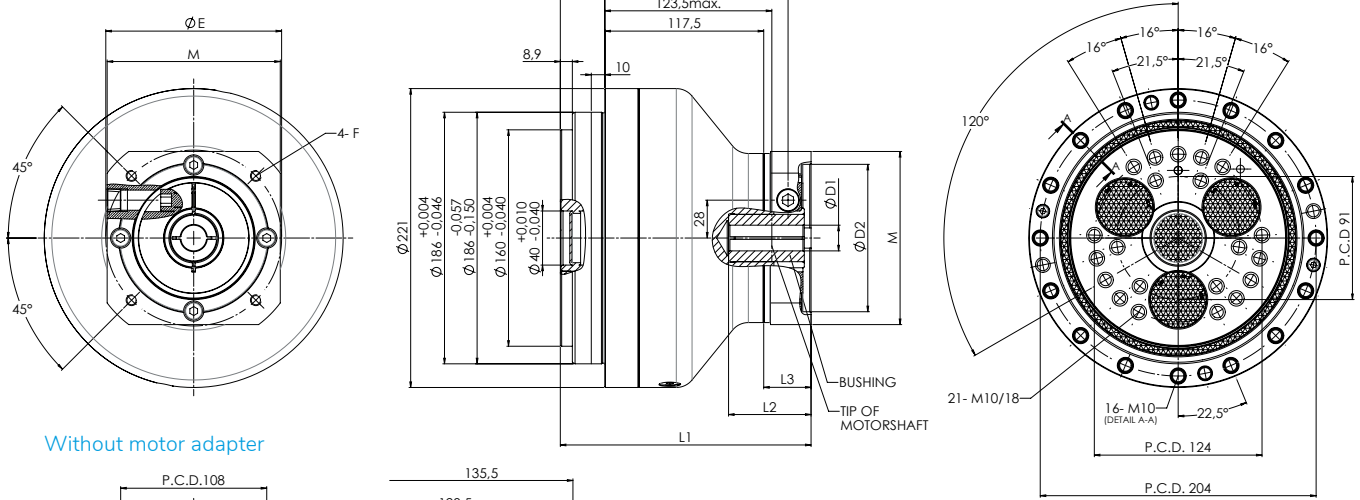

Without motor adapter

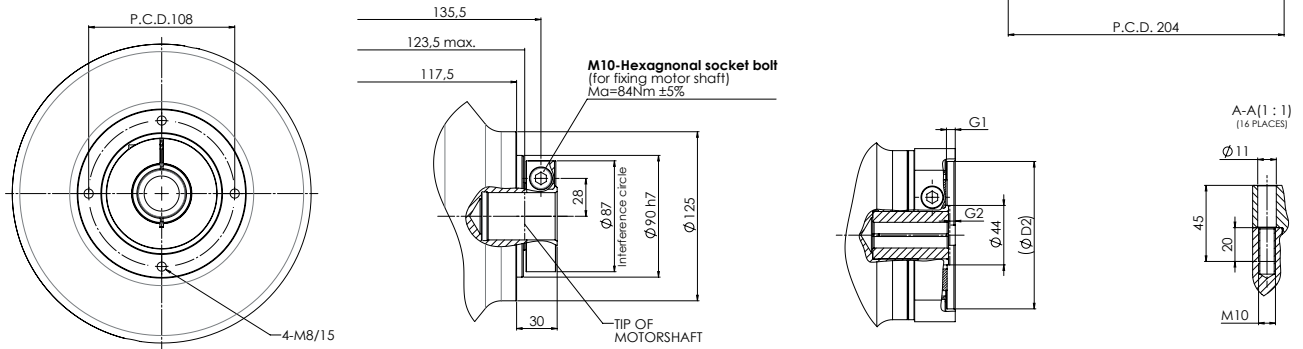

Technical drawing 125-B

With motor adapter

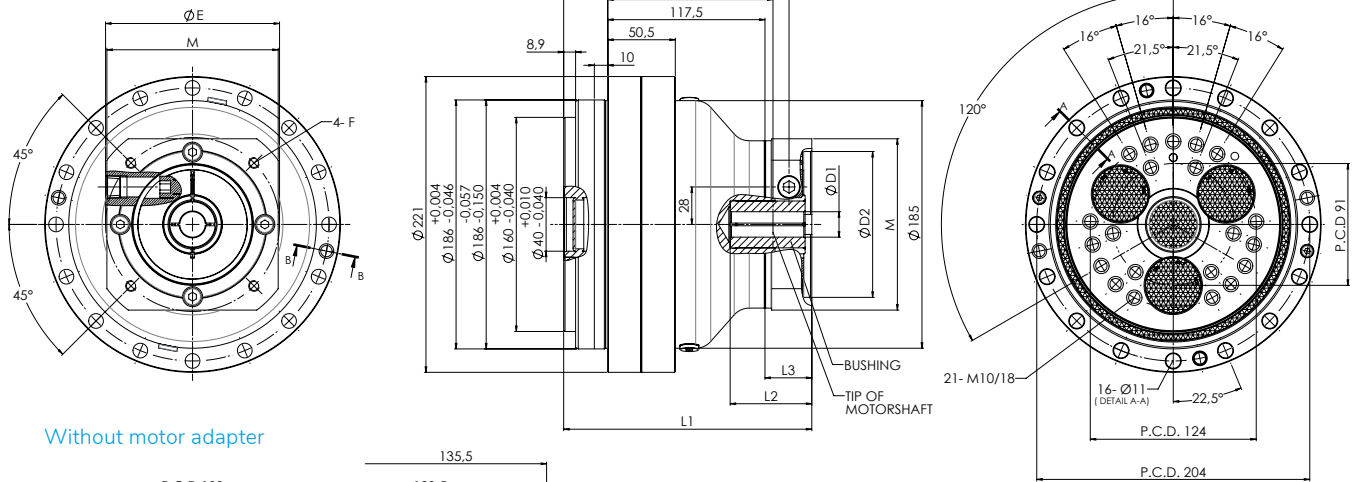

Without motor adapter

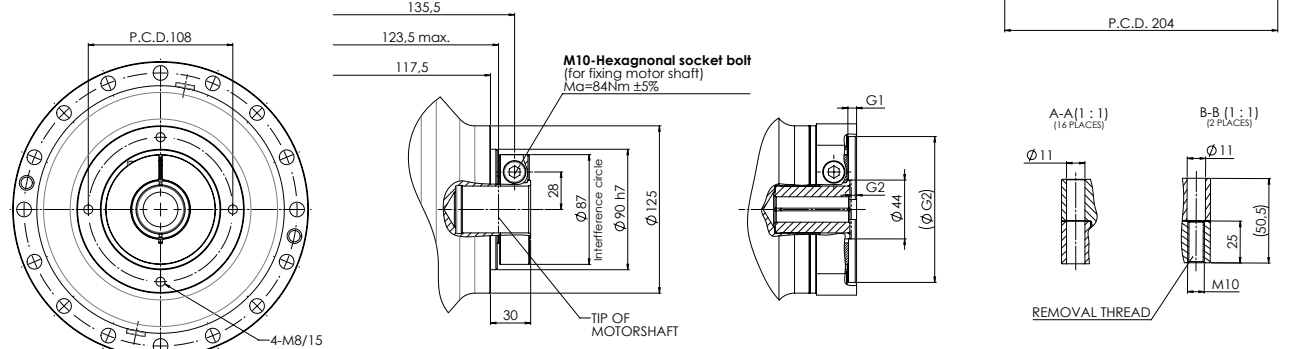

Series Neco®-125

Easy to size

Configure your desired gearbox quickly and easily in just 3 steps:

1. Ratio

Ratio					
41	81	102.17	121	145.61	161

2. Bushing

Code	B1 [mm]	B2 [mm]	LB [mm]
ZZZZ	35	without bushing	
F32A		32	56
F28A		28	
F25A		25	
F24A		24	
F22A		22	
F20A		20	
F19A		19	

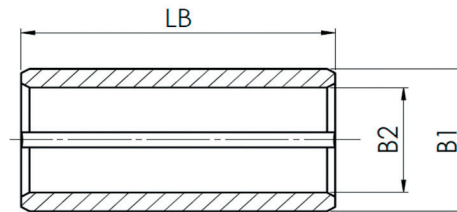

3. Motor adapter

Code	D1 [mm]	D2 [mm]	G1 [mm]	G2 [mm]	E [mm]	F [mm]	L1 [mm]	L2 [mm]	L3 [mm]	M [mm]	Gearbox Weight [kg]
ZZZZ	19 ... 35	without motor adapter									
VGFA		80F7	5	5	100	M6/12	187.4	30 ... 60	36	Ø 128	23.6
VGGA		95F7	11	25.5	145	M8/20	207.9	50 ... 80	56.5	□ 132	24.1
VGHA		110F7	6.5	4	130	M8/16	186.4	30 ... 60	35	□ 128	23.7
VGHC		110F7	6.5	9	130	M8/16	191.4	34 ... 66	40	□ 128	23.9
VGHB		110F7	8	15.5	145	M8/16	197.9	41 ... 71	46.5	□ 132	23.9
VGKA		130F7	5	4	165	M10/18	186.4	30 ... 60	35	□ 157	24.4

Series Neco[®]-160

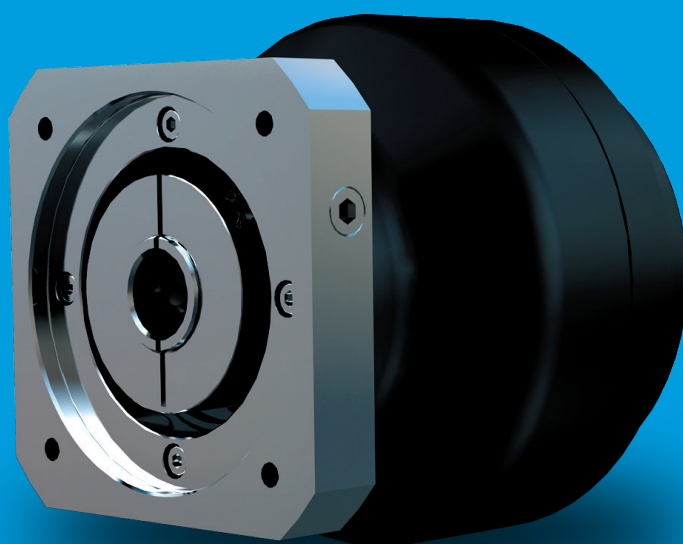

Series Neco®-160

Technical Data

Reference Product			*1	G1160Nx35...					
Rated Output Torque	T_0	Nm	*2	1,600					
Rated Output Speed	N_0	rpm	*2	15					
Rated Service Life	K	hrs	*2	6,000					
Ratio	R		*3	41	81	102.81	125.21	156	201
Allow. Acc./Dec. Torque	T_{S1}	Nm		4,000					
Mom.max.allow. Torque (E-Stop)	T_{S2}	Nm		8,000					
Allowable Output Speed [100 %]	N_{S0}	rpm	*4	19					
Allowable Output Speed [40 %]	N_{S1}	rpm	*4	48					
Hysteresis Loss		arc.min		0,5					
Angular Transm. Error (max.)		arc.sec		50					
Allow. Tilting Moment	M_{01}	Nm	*5	4,000					
Mom. Allow. Tilting Moment	M_{02}	Nm		8,000					
Allowable Radial Load	W_r	N	*6	20,619					
Torsional Rigidity (Ref.)		Nm/ arc.min		490					
Startup Efficiency (Typical Value)		%		80					
Ambient Temperature		°C		-10 ... +40					
Allowable Reducer Case Temperatur		°C	*7	-10 ... +60					
Surface Protection			*8	Standard Nabtesco SS-A and black oxidized. Motor adaptation in aluminum. (undefined corrosion protection class)					
Lubricant			*9	Nabtesco RV-Grease					
Motor Interface				Motor Interface acc. Customer request					
Motor Adaption	md	mm	*10	Ø 19 ... 35 k6/j6/h6			straight shaft (w/o Key Way)		
Connection Type				Radial Clamping Ring					
Limit Allow. Input Torque			*11	Depending on the selected reduction and/or motor shaft, a limitation may be necessary					

Series Neco®-160

Technical drawing 160-A

With motor adapter

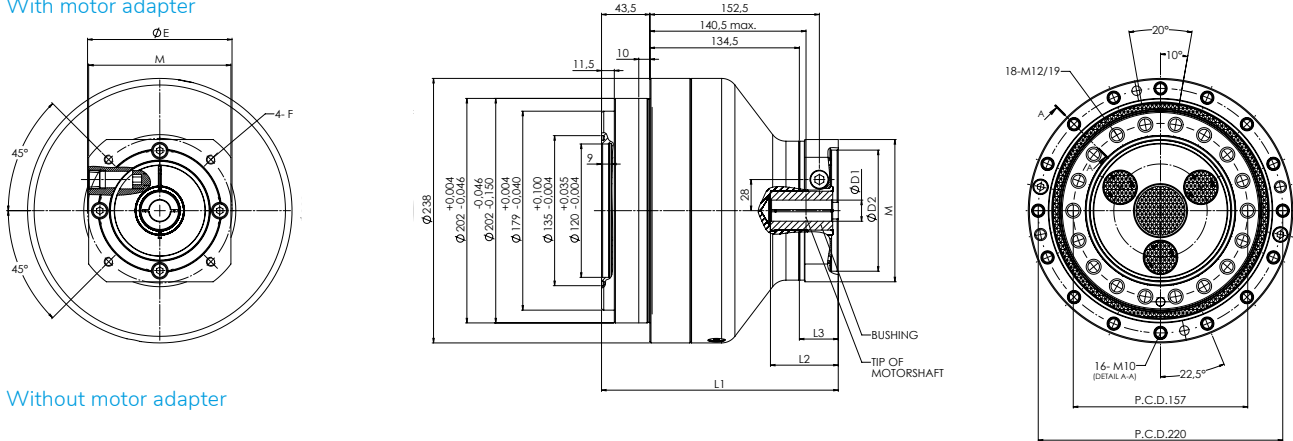

Without motor adapter

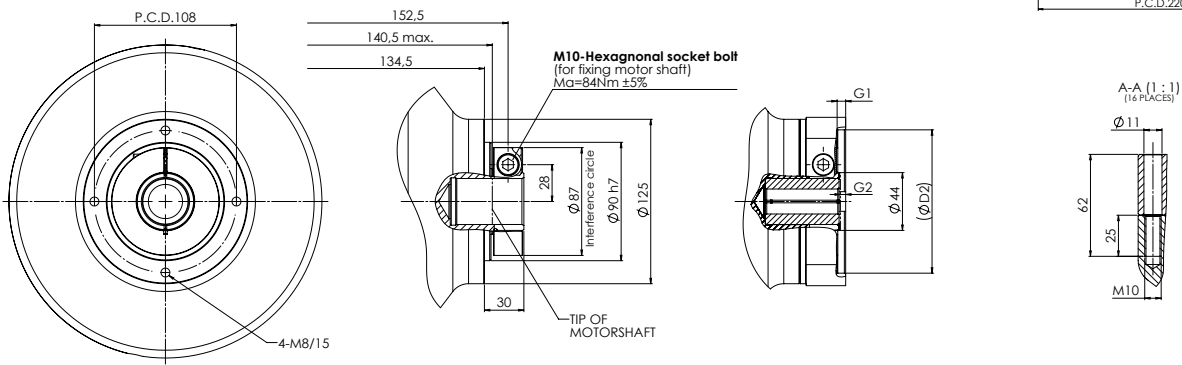

Technical drawing 160-B

With motor adapter

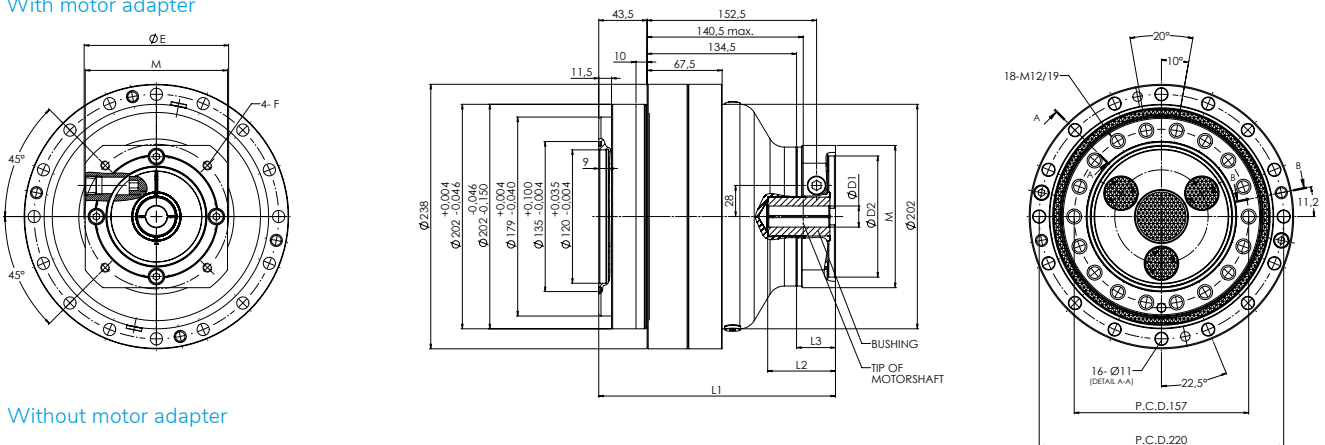

Without motor adapter

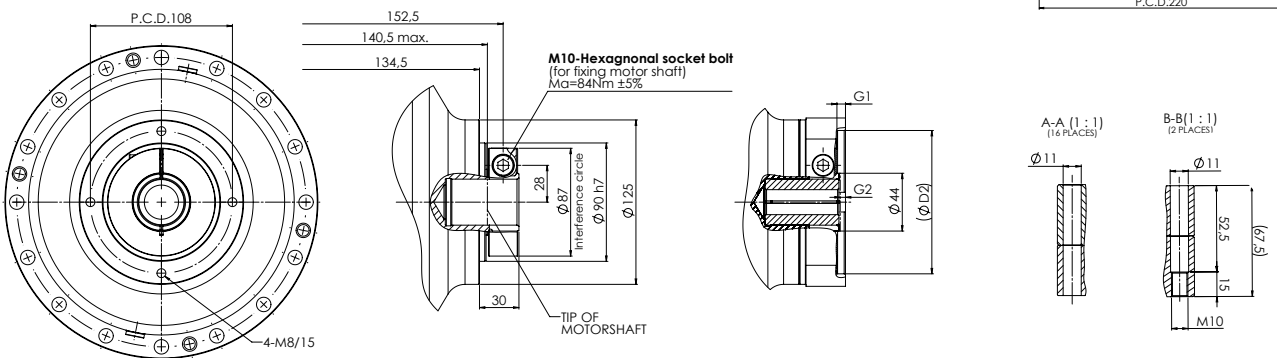

Series Neco®-160

Easy to size

Configure your desired gearbox quickly and easily in just 3 steps:

1. Ratio

Ratio					
41	81	102.81	125.21	156	201

2. Bushing

Code	B1 [mm]	B2 [mm]	LB [mm]
ZZZZ	35	without bushing	
F32A		32	56
F28A		28	
F25A		25	
F24A		24	
F22A		22	
F20A		20	
F19A		19	

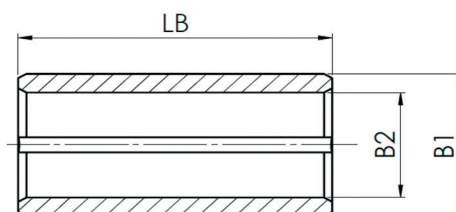

3. Motor adapter

Code	D1 [mm]	D2 [mm]	G1 [mm]	G2 [mm]	E [mm]	F [mm]	L1 [mm]	L2 [mm]	L3 [mm]	M [mm]	Gearbox Weight [kg]
ZZZZ	19 ... 35	without motor adapter									
VGFA		80F7	5	5	100	M6/12	215	30 ... 60	36	∅ 128	31.9
VGGA		95F7	11	25.5	145	M8/20	235.5	50 ... 80	56.5	□ 132	32.4
VGHA		110F7	6.5	4	130	M8/16	214	30 ... 60	35	□ 128	32
VGHC		110F7	6.5	9	130	M8/16	219	34 ... 66	40	□ 128	32.2
VGHB		110F7	8	15.5	145	M8/16	225.5	41 ... 71	46.5	□ 132	32.2
VGKA		130F7	5	4	165	M10/18	214	30 ... 60	35	□ 157	32.7

Notes

- *1 All technical data given below refer to products with the specified article code. Additional variants and information on demand
- *2 The rated torque is the value that produces the rated service life based on operation at the rated output speed. It does not indicate the maximum load.
- *3 Additional ratios on demand
- *4 The allowable output speed will differ depending upon the duty ratio, load, and ambient temperature. Contact us if the usage will be above the allowable output speed N_{s1} with a 40 % duty ratio.
- *5 The allowable moment will differ depending on the thrust load. Check the „Allowable Tilting Moment Diagram“
- *6 If the radial load is applied within main bearings span use reduction gear within the allowable radial load.
- *7 Temperature measured on the surface of reducer case
- *8 Please contact your sales partner for more detailed information.
- *9 Other lubricants on request
90 % filling (depending on the installation position and application, the optimal amount of lubricant may differ)
- *10 Adjustment of the motor shaft diameter via bushing. Permitted diameter tolerances must be observed.
A check of the motor interface by your sales partner is strongly recommended.
- *11 The max. permissible input torque results from the load limits of the gearbox specification.
Due to the design and configuration, there may be an additional limitation of the input torque.
Please contact your sales partner for further information.

Do you have any questions or need advice?

Please contact us.

Our team of experts will be glad to help you.

Fon: +49 211 17379-0

E-Mail: info@nabtesco.de

www.nabtesco.de

Origin of Photo Material:

Nabtesco Precision Europe GmbH, Köhler + Partner GmbH